

GeoMat Testing Laboratories, Inc.

Soil Engineering, Environmental Engineering, Materials Testing, Geology

March 14, 2016

Project No. 16027-01

TO: Mr. Shakil Patel, AIA
25982 Hinkley Street
Loma Linda, California 92354

SUBJECT: Preliminary Soil Investigation Report, Proposed Islamic Community Center, Northwest Corner of Beaumont Avenue and Nevada Street, APN 0293-111-15-0000, Redlands, California

Introduction

In accordance with your authorization, GeoMat Testing Laboratories, Inc., has performed a preliminary soils investigation at the subject site. The accompanying report presents a summary of our findings, conclusions, recommendations, and limitation of work for the proposed development.

The primary purpose of this investigation and report is to provide an evaluation of the existing geotechnical conditions at the site as they relate to the design and construction of the proposed development. More specifically, this investigation was aimed at providing geotechnical recommendations for earthwork, and design of foundations and pavements

If you have any questions regarding this report, please do not hesitate to call this office. We appreciate this opportunity to be of service.

Very truly yours,

GeoMat Testing Laboratories, Inc.

Haytham Nabilsli, GE2375
Principal Engineer

Art Martinez
Project Engineer



Distribution: (3) Addressee

ATTACHED FIGURES AND APPENDICES

Figure 1	Site Location Map
Figure 2	Geologic Map
Plate 1	Exploratory Borehole Location Map
Plate 2	Retaining Wall Drainage
Appendix A	References
Appendix B	Geotechnical Borehole Logs
Appendix C	Laboratory Test Results
Appendix D	CBC Seismic Design Parameters
Appendix E	General Earthwork and Grading Specifications

SCOPE OF WORK

The scope of our work included the following:

- Review soils, seismic, groundwater data, and maps in our files.
- Exploration of the site by means of a drill rig.
- Field engineer for logging, observe drilling resistance of boreholes.
- Sampling of select soils.
- Conduct laboratory testing of select soil samples for classification, direct shear, and sulfate.
- Prepare CBC seismic design parameters.
- Preparation of a soil investigation report to include: site preparation recommendations, overexcavation depth, allowable soil bearing value, foundation recommendations, slab-on-grade recommendations, earth pressures recommendations, grading specifications, concrete and asphalt pavement thickness, Site Class, and CBC seismic design parameters.

SUMMARY OF SITE CONDITION AND PROPOSED DEVELOPMENT

Site Conditions

The subject site is located on the northwestern corner of Beaumont Avenue and Nevada Street, Redlands, California. Both Beaumont Avenue and Nevada Street are paved streets without curb or gutter. The geographical relationship of the site and surrounding vicinity is shown on our Site Location Map, Figure 1.

The site is approximately five and a half acres. Topography of the site is generally flat with a maximum relief of 9 feet. Surface drainage sheeting flows to the northwest at a rate of approximately 1.3%. Currently the site is vacant with light seasonal grasses sparsely spread about.

Proposed Development

We understand that property is proposed for three structures, play fields, outdoor fountain, and large parking area.. The buildings cluster is located on the north half of the property.

It is anticipated that the proposed structure will be supported by a combination of isolated square and continuous wall type foundations, and concrete slabs-on-grade. We have not been provided with specific foundation loads. We anticipate however, that continuous wall loads will not exceed 3 to4 kips per linear foot and isolated column loads of up to 80 kips.

SUMMARY OF GEOTECHNICAL FINDINGS

Subsurface Exploration

Three exploratory boreholes were drilled on February 28, 2016, to a maximum depth of 15 feet below existing ground surface utilizing a CME 45 equipped with 6-inch hollows stem augers. Refer to Plate 1 for location of exploratory boreholes.

In general, boreholes revealed that the site is underlain by younger alluvial fan deposits to the maximum explored depth. The primary soils encountered are well-graded sand with gravel, well-graded sand with silt and gravel, silty sand, and sandy silt (USCS "SW", "SW-SM", "SM", and "ML", respectively) in the upper approximately fifteen feet.

Descriptions of the materials are presented in the form of Geotechnical Boring Logs in Appendix B.

Laboratory Testing

Laboratory moisture, density, sieve analysis, direct shear, and sulfate were performed on selected samples obtained from the boreholes. The soil classification is in conformance with the Unified Soil Classifications System (USCS), as outlined in the Classification and Symbols Chart (Appendix B). A graphical presentation of the test results is presented in Appendix C.

Groundwater

Groundwater study is not within the scope of this work. Groundwater was not encountered in our exploratory borings drilled at the site up to 15 feet below ground surface. Depth to groundwater is not expected to impact site grading.

Highest historical groundwater record documented by the State of California, Department of Water Resources in a well located approximately 1 mile northeast of the site (State Well No. 01S03W33C001S, elevation 1206) was 65 feet (water surface elevation of 1141) below ground surface on March 28, 1945. The lowest site elevation is approximately 1248 feet.

Please note that the potential for rain or irrigation water locally seeping through from elevated areas and showing up near grades cannot be precluded. Our experience indicates that surface or near-surface groundwater conditions can develop in areas where groundwater conditions did not exist prior to site development, especially in areas where a substantial increase in surface water infiltration results from landscape irrigation. Fluctuations in perched water elevations are likely to occur in the future due to variations in precipitation, temperature, consumptive uses, and other factors including mounding of perched water over bedrock. Mitigation for nuisance shallow seeps moving from elevated lower areas will be needed if encountered. These mitigations may include subdrains, horizontal drains, toe drains, french drains, heel drains or other devices.

Geologic Findings

Based on the USGS Preliminary Geologic Map of the Sunnymead/South 1/2 of Redlands Quadrangles, the site is mapped as young alluvium fan deposits consisting of unindurated and undissected alluvial sand gravel, and clay of valley areas, covered with thick soil.

Soil Type

Per Occupational Safety and Health Administration (OSHA) the site soils is classified as Soil Type "C".

Seismicity Considerations

Faults:

The subject site is not located within an Aloiquist-Priolo Earthquake Fault Zone. According to the California Department of Conservation, Fault Activity Map of California, the Rialto-Colton fault is closest to the site and located approximately 0.67 miles south-southwest of the site. However, since the site is located outside the fault zones and no faults are identified or reported onsite, surface rupture is not a hazard at this property. Regardless, a distinct potential exists for a high level of ground shaking during earthquakes.

Stability:

Subsequent to proposed grading there will be no slopes at the site, slope stability is not a hazard on this lot.

Tsunamis and Seiches

The site is inland and no lakes are nearby, therefore there is no potential danger from this hazard.

Liquefaction

Liquefaction is a mode of ground failure that results from the generation of high pore water pressures during earthquake ground shaking, causing loss of shear strength. Liquefaction is typically a hazard where loose sandy soils exist below groundwater. The CGS has designated certain areas within southern California as potential liquefaction hazard zones. These are areas considered at a risk of liquefaction-related ground failure during a seismic event, based upon mapped surficial deposits and the presence of a relatively shallow water table. According to the San Bernardino County's General Plan, Geologic Hazard Overlays, the site is not in an area susceptible to liquefaction.

Seismic Settlement

The site is not prone to liquefaction. Therefore, the potential for liquefaction associated ground deformation (seismic settlement and differential compaction) beneath the site is considered to be unlikely.

Site Class

It is our opinion that structures should be designed in accordance with the current seismic building code as determined by the structural engineer. The subject site is located in an estimated Site Class "D"

Ground Motion and Seismic Design Parameters:

The peak ground acceleration (PGA) and 2013 CBC seismic design parameters are presented in Appendix D.

Estimated Excavation Characteristics

The onsite soil appears to be medium dense to very dense. It may exhibit some resistance to excavation. Therefore, difficult excavation is not anticipated but should not be precluded. Excavation at the site may generate oversized material. This material, if encountered, should be removed from site.

Expansive Soil Characteristics

Based on the soils physical characteristics and laboratory classification, the upper foundation soils are sandy and considered to be very low in expansion potential.

CONCLUSIONS

- Vegetation, buried irrigation lines, old foundations, roots, utility lines, etc. may be encountered throughout the project area.
- The onsite soils, exclusive of deleterious material, may be used as compacted fill. Onsite soils are sandy and dry and will require significant watering during rough grading.
- Based on soil classifications, the expansion potential of the surface soils at the site is expected to be very low. This would require verification for the building pad subsequent to completion of rough grading.
- The use of shallow spread footings appears feasible for the proposed construction.
- The overall geologic situation of the item property is satisfactory for the intended use, provided the engineering designs are properly carried out.
- The site is expected to be subject to moderate to strong ground shaking from a regional seismic event within the projected life of the proposed structure.
- Liquefaction potential at the site is very low.
- No groundwater was encountered during our subsurface investigation to the maximum depth explored of 15 feet. However, perched water seepage moving locally from adjacent and higher areas cannot be precluded. Our experience indicates that surface or near-surface groundwater conditions can develop in areas where groundwater conditions did not exist prior to site development, especially in areas where a substantial increase in surface water infiltration results from landscape irrigation. We therefore recommend that local landscape irrigation and landscape irrigation from surrounding areas be kept to the minimum necessary to maintain plant vigor and that any leaking pipes/sprinklers, etc. should be promptly repaired.

We have no way of predicting depth to the groundwater which may fluctuate with seasonal changes and from one year to the next. Subdrains, horizontal drains or other devices may be recommended for areas that exhibit nuisance seepage.

RECOMMENDATIONS

Site Preparation

All grading should be performed in accordance with our General Earthwork and Grading Specifications presented in Appendix E except as modified within the text of this report.

Roots, oversized rocks, debris, abandoned utility lines, irrigation appurtenances, underground structures, old foundations, deleterious materials, etc., should be removed and hauled offsite. Cavities created during site clearance should be backfilled in a controlled manner.

Subsequent to site clearance, the building area should be overexcavated to a depth of at least 5-feet below existing grade. The lateral extent of overexcavation should include building pads, columns, patios, water fountain and should be at least equal to the depth of excavation, but no less than 5 feet. After overexcavation, the exposed surfaces should be scarified to a depth of at least 12-inches, watered and recompacted to at least 90 percent of the maximum dry density, as determined by ASTM D1557 Test Method; prior to placement of fill. Deeper overexcavation, especially to remove loose soils or deleterious material, may be required depending upon field observations of excavation bottom by the soil engineer or his representative.

Compacted Fills/Imported Soils

Any soil to be placed as fill, whether presently onsite or import, should be approved by the soil engineer or his representative prior to their placement. All onsite soils to be used as fill should be cleansed of any roots, or other deleterious materials. Cobbles and boulders, larger than 6-inches in diameter should not be placed in the vicinity of foundations and utility lines trenches.

All fills should be placed in 6- to -8 inch loose lifts, thoroughly watered, or aerated to near optimum moisture content, mixed and compacted to at least 90 percent relative compaction. This is relative to the maximum dry density determined by ASTM D1557 Test Method.

Any imported soils should be sandy (preferably USCS "SM" or "SW", and very low in expansion potential) and approved by the soil engineer. The soil engineer or his representative should observe the placement of all fill and take sufficient tests to verify the moisture content and the uniformity and degree of compaction obtained.

Tentative Foundation Recommendations

The use of shallow spread footings in compacted fill or firm native ground is feasible. A maximum allowable bearing value of 2000 psf is recommended for the following footing system.

- Depth of continuous and pad footings below natural and finish grade and below slab on grade should be at least 18 inches. Pad footings should measure at least 4 feet square feet.
- Footing reinforcement should be determined by the structural engineer; however, minimum reinforcement should be at least two No. 5 reinforcing bars, top and bottom.
- Expansion potential of foundation soils should be verified subsequent to footing excavation and before placement of footing material.
- The above recommended bearing value may be increased by one third for temporary (wind or seismic) loads.

Resistance to lateral footing will be provided by passive earth pressure and base friction. For footings bearing against firm native material, passive earth pressure may be considered to be developed at a rate of 271 psf per foot of depth to a maximum of 2000 psf. Base friction may be computed at 0.40 times the normal load. If passive earth pressure and friction are combined to provide required resistance to lateral forces, the value of the passive pressure should be reduced to two-thirds the value.

Foundation design comes under the purview of the structural engineer. The above recommendations should not preclude more restrictive structural requirements. The structural engineer should determine the actual footing sizes and reinforcement to resist vertical, horizontal, and uplift forces under static and seismic conditions.

Reinforcement and size recommendations presented in this report are considered the minimum necessary for the soil conditions present at foundation level and are not intended to supersede the design of the project structural engineer or criteria of the governing agencies for the project.

Earth Pressures

The following lateral earth pressures and soil parameters in conjunction with the above allowable soil bearing value for shallow foundation may be used for design of conventional retaining walls with free draining compacted backfills.

If passive earth pressure and friction are combined to provide required resistance to lateral forces, the value of the passive pressure should be reduced to two-thirds the following recommendations.

Active Earth Pressure with level backfill (P_a)	35 psf (EFP) drained, yielding
At Rest Pressure (P_0)	55 psf (EFP), drained, non-yielding (part of building wall)
Passive Earth Pressure (P_p)	271 psf (EFP), drained, maximum of 2000 psf
Horizontal Coefficient of Friction (μ)	0.40
Unit Soil Weight (γ_t)	120 pcf

All retaining walls and block wall footings should be founded in competent or compacted soil. We recommend drainage for retaining walls to be provided in accordance with the attached Plate 2. Drainage pipes and ditches should be connected to an approved drainage device. Maximum precautions should be taken when placing drainage materials and during backfilling. Wall backfill should be properly compacted to at least 90 percent relative compaction. Back-cut distance behind the top of wall should be at least 18 inches or other practical distance to facilitate compaction.

Modulus of Subgrade Reaction

A modulus of subgrade reaction of 150 pounds per cubic inch (pci) may be used for compacted alluvial soils.

Settlement

Proposed building will be supported on compacted fill. Native soils below the fill possess relatively high strengths and will not be subject to significant stress increases from the foundations of the new structure.

Therefore settlements are expected to be within tolerable limits. Total long-term settlement between similarly loaded adjacent foundation systems should not exceed one inch. The structures should be designed to tolerate a differential settlement on the order of 1/2 to 3/4-inch.

Concrete Flatwork

Slabs-on-grade may be at least four inches thick, reinforced with at least No 4 bars at 16-inches on-center both ways, properly centered in mid thickness of slabs. Slab-on-grades should be underlain with four inches of sand. If moisture intrusion is objectionable, the concrete slab should be provided by a 10-mil Visqueen moisture barrier placed and sealed over the sand.

Slab-on-grade thickness and reinforcement should be evaluated by the structural engineer and designed in compliance with applicable codes. Excess soils generated from foundation excavations should not be placed on any building pads without proper moisture and compaction. All slab subgrades should be verified to be saturated to a depth of 12 inches prior to placement of slab building materials. Moisture content should be tested in the field by the soil engineer. Slabs subgrade should be kept moist and the surface should not be allowed to desiccate.

The addition of fiber mesh in the concrete and careful control of water/cement ratios may lessen the potential for slab cracking. In hot or windy weather, the contractor must take appropriate curing precautions after the placement of concrete.

The use of mechanically compacted low slump concrete (not exceeding 4 inches at the time of placement) is recommended. We recommend that a slipsheet (or equivalent) be utilized if grouted tiles or other crack sensitive flooring (such as marble tiles) is planned directly on concrete slabs.

Cement Type/Corrosion Potential

Laboratory testing conducted for a soil sample showed that water soluble sulfate is less than 0.015 percent (negligible sulfate exposure risk). We recommend Type II cement for all concrete work in contact with soil. Ferrous metal pipes should be protected from potential corrosion by bituminous coating, etc. We recommend that all utility pipes be nonmetallic and/or corrosion resistant.

Recommendations should be verified by soluble sulfate and corrosion testing of soil samples obtained from specific locations at the completion of grading.

Temporary Excavations

General

All excavations must comply with applicable local, state, and federal safety regulations including the current OSHA Excavation and Trench Safety Standards.

Construction site safety generally is the sole responsibility of the Contractor, who should also be solely responsible for the means, methods, and sequencing of construction operations.

Safe Vertical Cut

Temporary un-surcharged excavations of 4 feet high may be made at a vertical gradient for short periods of time. Temporary un-surcharged excavations above 4 feet high may be trimmed at 1.5H:1V gradient.

Onsite soils are sandy and can easily unravel. In areas where soils have little or no binder, shoring of deep excavation may be required.

Exposed condition during construction should be verified by the project geotechnical engineer. No excavations should take place without the direct supervision of the project geotechnical engineer.

All applicable requirements of the California Construction and general Industry Safety Orders, the Occupational Safety and Health Act, and current amendments, and the Construction Safety Act should be met. Cuts should be observed during excavation by the project's geotechnical consultant. If potentially unstable soil conditions are encountered, modifications of slope ratios for temporary cuts may be required.

Precaution for Excavations

The Contractor should be aware that unsupported excavation depths should in no case exceed those specified in local, state, and/or federal safety regulations (e.g., OSHA Health and Safety Standards for Excavations, 29 CFR Part 1926, or successor regulations).

Such regulations are strictly enforced and, if they are not followed, the Owner, Contractor, and/or earthwork and utility subcontractors could be liable for substantial penalties. The contractor's "responsible person", as defined in 29 CFR Part 1926, should evaluate the soil exposed in the excavations as part of the contractor's safety procedures. In no case should slope height, slope inclination, or excavation depth, including utility trench excavation depth, exceed those specified in local, state, and federal safety regulations.

Sloping the sides of temporary excavations should be required beyond the recommended safe cut where trench/excavation is expected to be left open for a long time or where trench/excavation is along foundation or where adjacent utilities exist or public right-of-way. Temporary excavation should not extend below a 1H:1V plane extending beyond and down from the bottom of the existing utility lines or structures.

Site Drainage

Positive drainage should be provided and maintained for the life of the project around the perimeter of all structures and all foundations toward streets or approved drainage devices to minimize water infiltrating into the underlying natural and engineered fill soils, and prevent erosion from slopes.

In addition, finish subgrade adjacent to exterior footings should be sloped down (at least 2%) and away to facilitate surface drainage. Roof drainage should be collected and directed away from foundations via nonerosive devices. Water, either natural or by irrigation, should not be permitted to pond or saturate the foundation soils or slopes. Over the slope drainage should not be permitted.

Planter areas and large trees adjacent to the foundations are not recommended. All planters and terraces should be provided with drainage devices. Location of drainage device should be in accordance with the design civil engineers drainage and erosion control recommendations.

The owner should be made aware of the potential problems, which may develop when drainage is altered through construction of walls and other devices. Ponded water, leaking irrigation systems, over watering or other conditions which could lead to ground saturation should be avoided. Surface and subsurface runoff from adjacent properties should be controlled. Area drainage collection should be directed toward the existing street through approved drainage devices. All drainage devices should be properly maintained.

Trench Backfill

All utility trenches and retaining wall backfills should be mechanically compacted to the minimum requirements of at least 90 percent relative compaction. Onsite soils derived from trench excavations can be used as trench backfill except for deleterious materials. Soils with sand equivalent greater than 30 may be utilized for pipe bedding and shading. Pipe bedding should be required to provide uniform support for piping. Excavated material from footing trenches should not be placed in slab-on-grade areas unless properly compacted and tested.

Tentative Asphalt Pavement

On the basis of classifications of onsite soils, an assumed Traffic Indices, and estimated R-value of 50, the minimum recommended pavement thickness is as follows:

Location	Traffic Index	Minimum Recommended Pavement Section	Full Depth AC Pavement Section
Parking Areas	5.0	3.0" AC over 4.0" Aggregate Base	4.5"
Driveways	6.0	3.5" AC over 4.0" Aggregate Base	5.5"

All pavement subgrade should be cleared of any deleterious material and overexcavated to a depth of at least 12 inches below existing or finished grade, whichever is deeper. The bottom of the excavation should be further scarified an additional 12 inches, moisture conditioned, and compacted to at least 90 percent of the maximum density as determined by ASTM D1557 test method. Aggregate base should be compacted to at least 95 percent of the maximum density as determined by ASTM D1557 test method.

If subgrade soils possess an R-Value equivalent to 30 or higher, a full AC pavement depth may be utilized. If the full depth is to be used, subgrade soils should be compacted to at least 95 percent of the maximum density as determined by ASTM D1557 test method.

Final pavement design recommendations should be based on laboratory test results of representative pavement subgrade soils upon the completion of rough grading.

Optional Tentative Concrete Pavement

For interior private drives, 5 inches minimum concrete over compacted native subgrade is recommended. Pavement subgrade should be saturated to a depth of 12 inches and compacted to at least 95 percent relative compaction. Saturated subgrade should be tested for moisture by the soil engineer.

Concrete pavement should be air entrained Portland Cement Concrete Pavement and must have a minimum 28-day flexural strength of 570 psi (compressive strength of approximately 4000 psi).

No reinforcing is necessary. Joint design and spacing should be in accordance with ACI recommendations. Construction joints should contain dowels or be tongue and grooved to provide load transfer. Tie bars are recommended on the joints adjacent to unsupported edges. Maximum joint spacing in feet should not exceed 2 to 3 times the thickness in inches. Joint sealing with a quality silicone sealer is recommended to prevent water from entering the subgrade allowing pumping and loss of support.

Proper subgrade preparation and joint sealing will reduce (but not eliminate) the potential for slab movements (thus cracking) on native soils. Frequent jointing will reduce uncontrolled cracking and increase the efficiency of aggregate interlock joint transfer.

Trash Enclosure

The trash enclosure slab should consist of a minimum 6 inches concrete and should be reinforced with at least #4 rebars (both ways) at 16-inch center-to-center spacing. The required slab thickness and reinforcement should be designed by the project structural engineer. Shrinkage control and construction joints should be considered by the trash enclosure slab designer.

Based on our previous experience, there is a tendency for early pavement damage in front of the trash enclosure area, where heavy wheel loads are concentrated in the same location. To enhance the durability of this paved area and reduce maintenance costs, a minimum 8 inch concrete stress apron should be constructed.

The concrete pavement should be air entrained Portland Cement Concrete Pavement and must have a minimum 28-day flexural strength of 570 psi (compressive strength of approximately 4000 psi). At a minimum, the concrete apron pavement should be reinforced with #4 rebar (both ways) at 16-inch center-to-center spacing. Shrinkage control and construction joints should be considered by the PCC pavement designer.

The apron should be installed to cover the front of the enclosure and extend out an additional 8 feet minimum from the enclosure opening. The subgrade soils should be placed in thin lifts in a manner to prevent segregation; uniformly moisture conditioned to near optimum moisture content, and compacted to at least 95 percent relative compaction to provide a smooth, unyielding surface. The upper 12 inches of subgrade under the concrete stress apron should be saturated and tested for saturation.

Construction Observation/Testing/Plan Review

The recommendations provided in this report are based on preliminary information and subsurface conditions as interpreted from limited exploratory borings at the site. We should be retained to review final grading and foundation plans to revise our conclusions and recommendations, as necessary. Our conclusions and recommendations should be reviewed and verified during site grading, and revised accordingly if exposed geotechnical conditions vary from our preliminary findings and interpretations.

Additional Observation and/or Testing

GeoMat Testing Laboratories, Inc. should observe and/or test at the following stages of construction.

- During all overexcavations and fill placement.
- Following footing excavation and prior to placement of footing materials.
- During wetting of slab subgrade and prior to placement of slab materials.
- During all trench and retaining wall backfill.
- When any unusual conditions are encountered.

Final Report of Compaction During Grading

A final report of compaction control should be prepared subsequent to the completion of grading. The report should include a summary of work performed, laboratory test results, and the results and locations of field density tests performed during grading.

GEOTECHNICAL RISK

The concept of risk is an important aspect of the geotechnical evaluation. The primary reason for this is that the analytical methods used to develop geotechnical recommendations do not comprise an exact science. The analytical tools which geotechnical engineers use are generally empirical and must be used in conjunction with engineering judgment and experience. Therefore, the solutions and recommendations presented in the geotechnical evaluation should not be considered risk-free and, more importantly, are not a guarantee that the interaction between the soils and the proposed structure will perform as planned. The engineering recommendations presented in the preceding sections constitute GeoMat Testing Laboratories professional estimate of those measures that are necessary for the proposed structure to perform according to the proposed design based on the information generated and referenced during this evaluation, and GeoMat Testing Laboratories experience in working with these conditions.

LIMITATION OF INVESTIGATION

This report was prepared for the exclusive use on the project team. The use by others, or for the purposes other than intended, is at the user's sole risk.

Our investigation was performed using the degree of care and skill ordinarily exercised, under similar circumstances, by reputable Geotechnical Engineers practicing in this or similar locations within the limitations of scope, schedule, and budget. No other warranty, expressed or implied, is made as to the conclusions and professional advice included in this report.

The field and laboratory test data are believed representative of the site; however, soil conditions can vary significantly. As in most projects, conditions revealed during construction may be at variance with preliminary findings. If this condition occurs, the possible variations must be evaluated by the Project Geotechnical Engineer and adjusted as required or alternate design recommended.

This report is issued with the understanding that it is the responsibility of the owner, or his representative, to ensure that the information and recommendations contained herein are brought to the attention of the architect and engineer for the project and incorporated into the plans, and the necessary steps are taken to see that the contractor and subcontractor carry out such recommendations in the field.

This firm does not practice or consult in the field of safety engineering. We do not direct the contractor's operations, and we cannot be responsible for other than our own personnel on the site; therefore, the safety of others is the responsibility of the contractor. The contractor should notify the owner if he considers any of the recommended actions presented herein to be unsafe.

The findings, conclusions, and recommendations presented herein are based on our understanding of the project and on subsurface conditions observed during our site work, and are valid as of the present date. However, changes in the conditions of a property can occur with the passage of time, whether they be due to natural processes or the works of man on this or adjacent properties. In additions, changes in applicable or appropriate standards may occur, whether they result from legislation or the broadening of knowledge.

The findings of this report are valid as of the present date. However, changes in the conditions of a property can occur with the passage of time, whether they be due to natural processes or the works of man on this or adjacent properties. In additions, changes in applicable or appropriate standards may occur, whether they result from legislation or the broadening of knowledge.

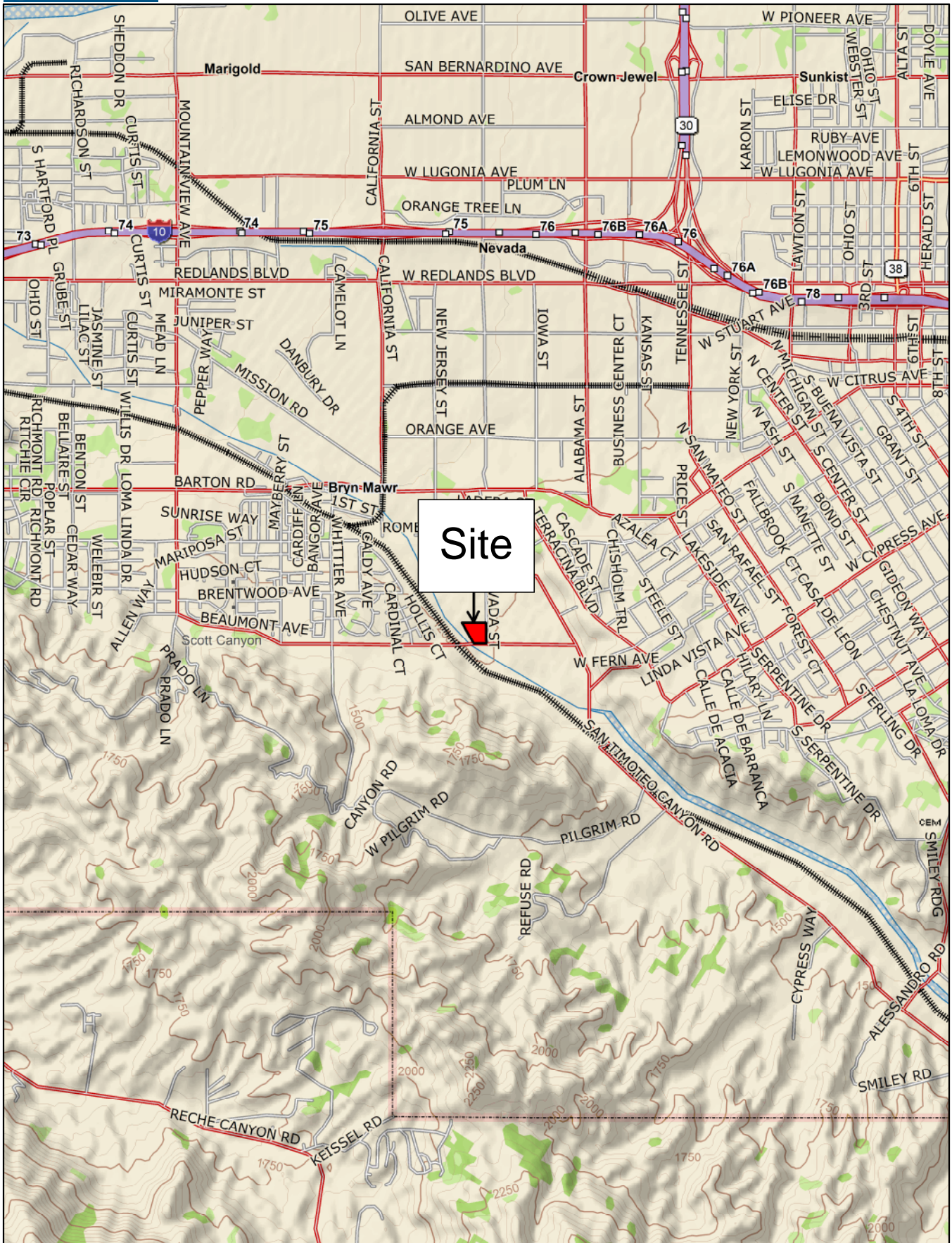

Data use subject to license.

© 2006 DeLorme. Topo USA® 6.0.

www.delorme.com



Scale 1 : 50,000

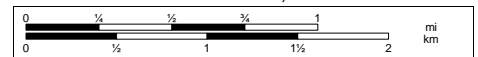

1" = 4,166.7 ft

Data Zoom 12-0

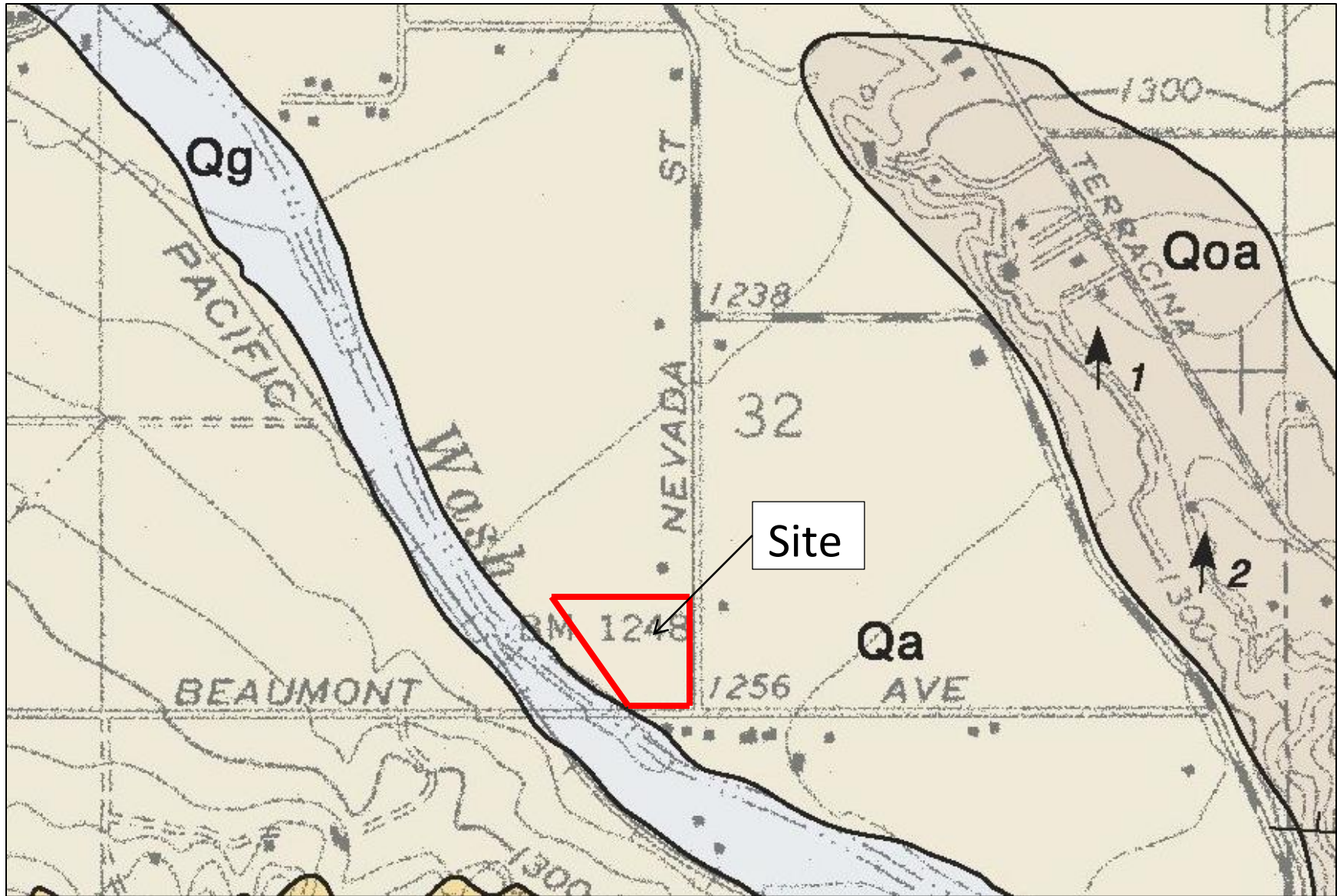

0 500 1000



Approximate Scale (ft)

EXPLANATION

- Qa: Alluvial Sand, Gravel, and Clay of Valley Areas
- Qoa: Older Alluvial Fan Deposits
- Qg: Alluvial Gravel and Sand of Stream Channels

Geologic Map

NWC Beaumont Ave & Nevada St.
Redlands, California

Date: 3/10/2016

Project No.: 16027-01

Figure: 2



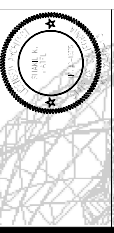

DATE: 03/11/16
 SHEET TITLE: SITE PLAN PHASE III
 PROJECT NO: 16027-01
 DRAWN BY: SP
 CHECKED BY: SP

ISLAMIC COMMUNITY CENTER OF REDLANDS
 CENTER OF REDLANDS
 NORTH WEST CORNER OF BEAUMONT AVENUE AND NEVADA STREET

MASTER PLANNING PHASE III

OF A103

PROJECT DATA

OWNER: ISLAMIC COMMUNITY CENTER OF REDLANDS
 15802 HINCKLEY STREET, LAJOLLA, CA 92034
 (951) 752-7200
 sha@shahli.com

APPLICANT: SHAHLI PATEL & ASSOCIATES-ARCHITECTS
 15802 HINCKLEY STREET, LAJOLLA, CA 92034
 (951) 752-7200
 sha@shahli.com

ASSessor PARCEL NUMBER: APN 0293-111-15-0000

ZONING: RL - MULTI FAMILY RESIDENCE

GENERAL PLAN LAND USE: MULTI-FAMILY RESIDENCE

FRONT SETBACK: 25'-0"

SIDE SETBACK: 25'-0"

REAR SETBACK: 25'-0"

SITE DATA: 5.50 AC
 LOT AREA: 415,000 SF
 BUILDING OCCUPANCY: 19,500 SF
 FIRST FLOOR: 19,500 SF

BUILDING DATA: 19,500 SF
 LANDSCAPE AREA: 10,150 SF
 LOT COVERAGE: 5.60 %
 PHASE II (NEXT 5 YEARS): 7,870 SF
 PHASE II (NEXT 10 YEARS): 6,800 SF
 TOTAL LOT COVERAGE REQUIRED: 26,600 SF @ 12 %
 MAXIMUM HEIGHT: 35 FEET

PARKING CALCULATION: 41,000 SF - 124 STALLS
 17,000 SF - 6 STALLS
 HANDICAPPED STALLS: 1,000 SF @ 100 SF / STALL
 ACCESSORY AREA: 12,000 SF @ 100 SF / STALL
 REQUIRED STALLS: 238 STALLS

UTILITIES: PRIVATE
 WATER: LOVA LINQ / PRIVATE
 ELECTRICAL: SCE
 GAS: SERRA DISTRICT
 SEWER: REDLANDS UNITED SCHOOL DISTRICT

According to the Hazardous Overlay Map, the Project site is within a FEMA Flood Zone X.

VICINITY MAP

PROPOSED SITE

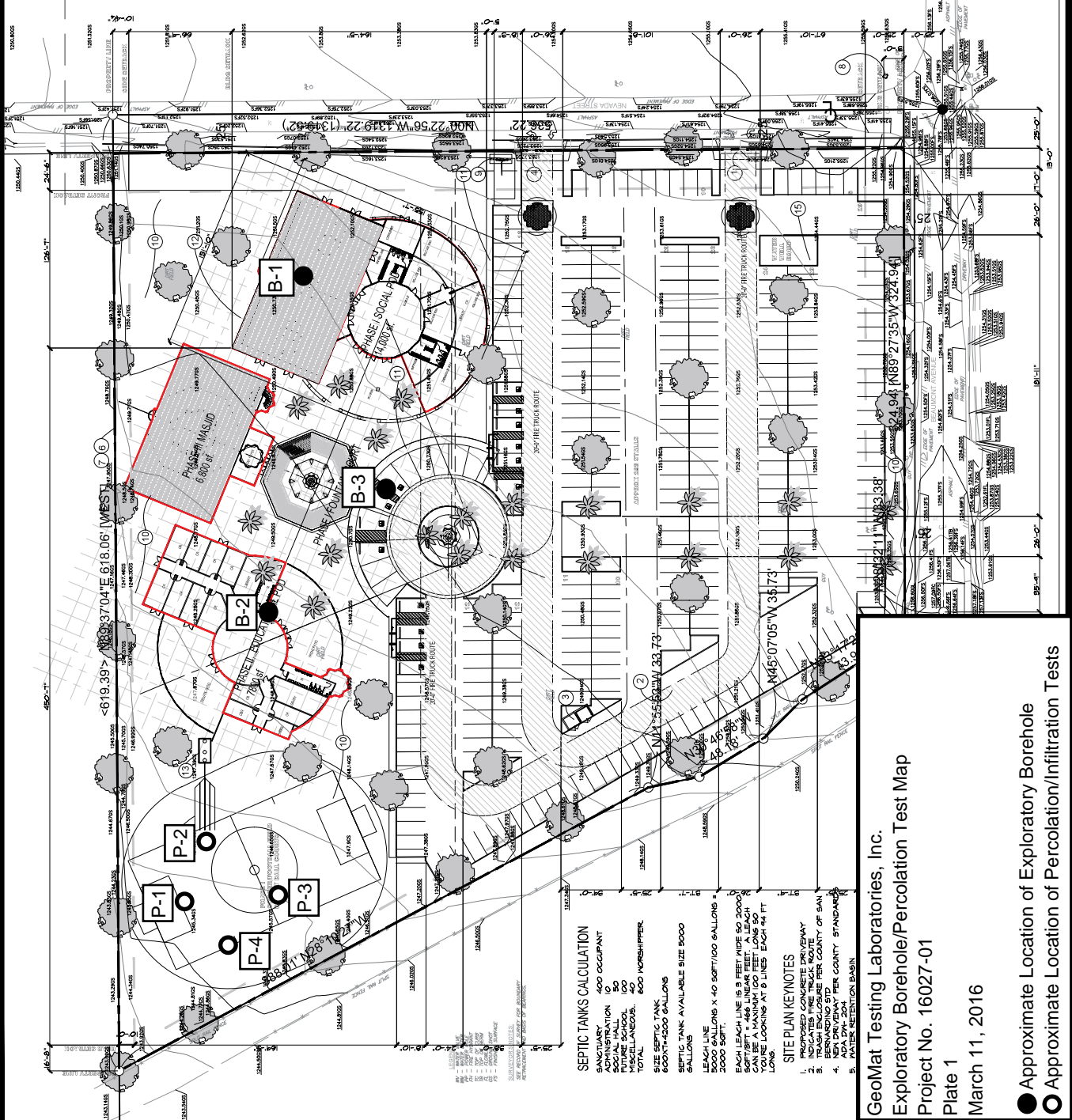
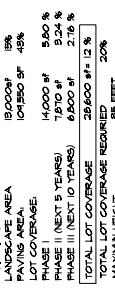

SEPTIC TANKS CALCULATION

SANITARY: 400 OCCUPANT
 ADMINISTRATION: 50
 SOCIAL HALL: 150
 MISCELLANEOUS: 500
 TOTAL: 600 NORTHPIPER

SIZE SEPTIC TANK: 600X1400 GALLONS
 SEPTIC TANK AVAILABLE SIZE: 5000 GALLONS

LEACH LINES: 4 X 40' @ 50 FT/100 GALLONS = 2000 SQ FT

EACH LEACH LINE IS 8 FEET WIDE @ 2000 SQ FT @ 40' LINEAR FEET, A LEACH LINE CAN BE A MAXIMUM 100 FEET LONG @ 40' LINEAR FEET @ 8 LINES, EACH 44 FT LONG.

SITE PLAN KEY/NOTES

- INDICATED FIRE TRUCK ROUTE
- TRASH ENCLOSURE PER COUNTY OF SAN DIEGO
- NEW DRIVEWAY PER COUNTY STANDARDS
- NEW DRIVEWAY PER COUNTY STANDARDS
- NEW DRIVEWAY PER COUNTY STANDARDS

GeoMat Testing Laboratories, Inc.
 Exploratory Borehole/Percolation Test Map
 Project No. 16027-01
 Plate 1
 March 11, 2016

- Approximate Location of Exploratory Borehole
- Approximate Location of Percolation/Infiltration Tests

SUBDRAIN OPTIONS AND BACKFILL WHEN NATIVE MATERIAL HAS EXPANSION INDEX OF ≤ 50

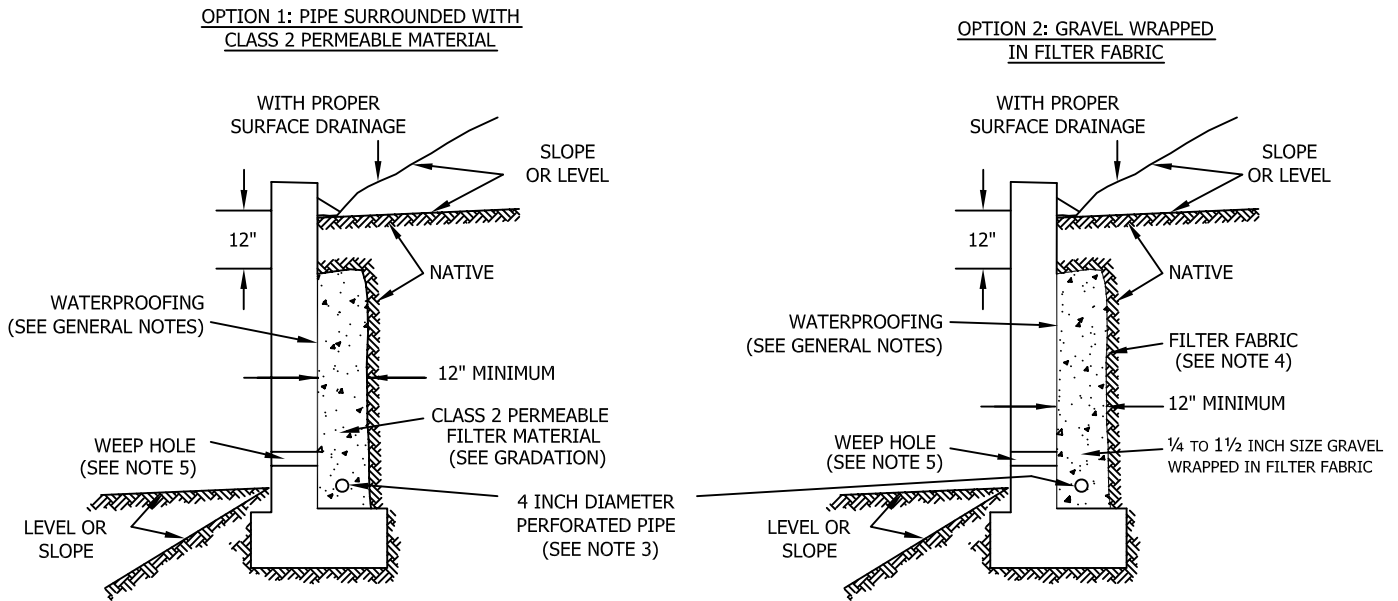

Class 2 Filter Permeable Material Gradation
Per Caltrans Specifications

<u>Sieve Size</u>	<u>Percent Passing</u>
1"	100
3/4"	90-100
3/8"	40-100
No. 4	25-40
No. 8	18-33
No. 30	5-15
No. 50	0-7
No. 200	0-3

GENERAL NOTES:

- * Waterproofing should be provided where moisture nuisance problem through the wall is undesirable.
- * Water proofing of the walls is not under purview of the geotechnical engineer
- * All drains should have a gradient of 1 percent minimum
- * Outlet portion of the subdrain should have a 4-inch diameter solid pipe discharged into a suitable disposal area designed by the project engineer. The subdrain pipe should be accessible for maintenance (rodding)
- * Other subdrain backfill options are subject to the review by the geotechnical engineer and modification of design parameters.

Notes:

- 1) Sand should have a sand equivalent of 30 or greater and may be densified by water jetting.
- 2) 1 Cu. ft. per ft. of 1/4- to 1 1/2-inch size gravel wrapped in filter fabric
- 3) Pipe type should be ASTM D1527 Acrylonitrile Butadiene Styrene (ABS) SDR35 or ASTM D1785 Polyvinyl Chloride plastic (PVC), Schedule 40, Armco A2000 PVC, or approved equivalent. Pipe should be installed with perforations down. Perforations should be 3/8 inch in diameter placed at the ends of a 120-degree arc in two rows at 3-inch on center (staggered)
- 4) Filter fabric should be Mirafi 140NC or approved equivalent.
- 5) Weephole should be 3-inch minimum diameter and provided at 10-foot maximum intervals. If exposure is permitted, weepholes should be located 12 inches above finished grade. If exposure is not permitted such as for a wall adjacent to a sidewalk/curb, a pipe under the sidewalk to be discharged through the curb face or equivalent should be provided. For a basement-type wall, a proper subdrain outlet system should be provided.
- 6) Retaining wall plans should be reviewed and approved by the geotechnical engineer.
- 7) Walls over six feet in height are subject to a special review by the geotechnical engineer and modifications to the above requirements.

RETAINING WALL BACKFILL AND SUBDRAIN DETAIL

WHEN NATIVE MATERIAL HAS EXPANSION INDEX OF ≤ 50

Plate 2

Appendix A

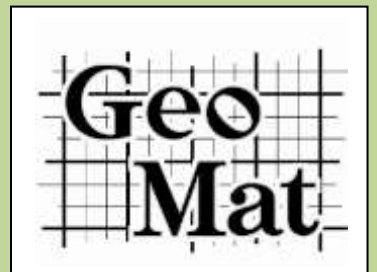

REFERENCES

Shakil Patel & Associates' Islamic Community Center of Redlands, Northwest Corner of Beaumont Avenue and Nevada Street, Redlands, California, Site Plan Phase III, Sheet A103, Plan Dated February 2, 2016.

USGS, Geologic Map of the Sunnymead and South 1/2 Redlands Quadrangles, Thomas W. Dibblee, Jr., 2003.

Geologic Map of the San Bernardino and Santa Ana 30'x60' Quadrangles, California, Version 1.0, Morton and Miller, 2006.

San Bernardino County Land Use Plan, General Plan, Geologic Hazard Overlays, FH31C, Redlands

State of California, Department of Water Resources, Water Data Library.

State of California, Department of Conservation, CGS Information Warehouse: Regulatory Maps

USGS, Earthquake Hazards Program, U.S. Seismic Design Maps

Department of the Navy, Design Manual 7.01, Soil Mechanics, September 1986.

Department of the Navy, Design Manual 7.02, Foundation and Earth Structures, September 1986.

Department of the Army, US Army Corps of Engineers, Engineering and Design, Bearing Capacity of Soils, EM 1110-1-1905.

ASCE, Journal of Geotechnical Engineering, Vol 118, 1987, "Evaluation of Settlements in Sand Due to Earthquake Shaking.", by K. Tokimatsu and H.B. Seed, p. 871, 876.

Foundation Design, D. Cudoto, Second Edition, 2000.

Principals of Foundation Design, Braja Das.

Foundation Analysis and Design, Ed. 5 by Joseph E. Bowles.

Robert Day, Geotechnical Engineer's Portable Handbook.

Robert Day, Geotechnical Foundation Handbook.

Appendix B

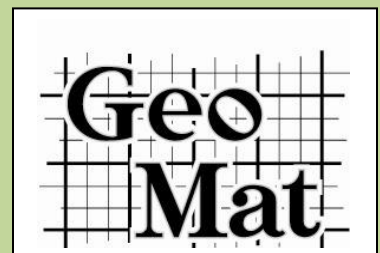

WATER LEVEL MEASUREMENTS

Water levels indicated on the boring logs are levels measured in the borings at the times indicated. In permeable materials, the indicated levels may reflect the location of groundwater. In low permeability soils, the accurate determination of groundwater levels is not possible with only short-term observations.

WATER LEVEL OBSERVATION DESIGNATION

W.D.	While Drilling
A.B.	After Boring
B.C.R.	Before Casing Removal
A.C.R.	After Casing Removal
24 hr.	Water level taken approximately 24 hrs. after boring completion

DRILLING AND SAMPLING SYMBOLS

AS	Auger Sample
CS	Continuous Sampler
DB	Diamond Bit -NX unless otherwise noted
HA	Hand Auger
HS	Hollow Stem Auger
PA	Power Auger
RB	Rock Bit
SS*	Split-Barrel
ST	Shelby Tube - 2" (51mm) unless otherwise noted
WB	Wash Bore
CR	California Ring Sampler 3" O.D., Lined with 2.5"X1" Rings

*The Standard Penetration Test is conducted in conjunction with the split-barrel sampling procedure. The "N" value corresponds to the number of blows required to drive the last 1 foot (0.3m) of an 18 in. (0.46m) long, 2 in. (51mm) O.D. split-barrel sampler with a 140 lb. (63.5 kg) hammer falling a distance of 30 in. (0.76m). The Standard Penetration Test is carried out according to ASTM D-1586. (See "N" Value below.)

SOIL PROPERTIES & DESCRIPTIONS

TEXTURE

PARTICLE	SIZE
Clay	< 0.002 mm (< 0.002 mm)
Silt	< #200 Sieve (0.075 mm)
Sand	#4 to #200 Sieve (4.75 to 0.075 mm)
Gravel	3 in. to #4 Sieve (75 mm to 4.75 mm)
Cobbles	12 in. to 3 in. (300 mm to 75 mm)
Boulders	> 12 in. (300 mm)

COMPOSITION

SAND & GRAVEL	
Description	% by Dry Weight
trace	< 15
with modifier	15 - 29
	> 30
FINES	
Description	% by Dry Weight
trace	< 5
with modifier	5 - 12
	> 12

Soil descriptions are based on the Unified Soil Classification System (USCS) as outlined in ASTM Designations D-2487 and D-2488. The USCS group symbol shown on the boring logs correspond to the group names listed below. The description includes soil constituents, consistency, relative density, color and other appropriate descriptive terms. Geologic description of bedrock, when encountered, also is shown in the description column.

GROUP SYMBOL	GROUP NAME	GROUP SYMBOL	GROUP NAME
GW	Well Graded Gravel	CL	Lean Clay
GP	Poorly Graded Gravel	ML	Silt
GM	Silty Gravel	OL	Organic Clay or Silt
GC	Clayey Gravel	CH	Fat Clay
SW	Well Graded Sand	MH	Elastic Silt
SP	Poorly Graded Sand	OH	Organic Clay or Silt
SM	Silty Sand	PT	Peat
SC	Clayey Sand	CL-CH	Lean to Fat Clay

COHESIVE SOILS

CONSISTENCY	UNCONFINED COMPRESSIVE STRENGTH (Qu) (psf)	COMPRESSIVE STRENGTH (Qu) (kPa)	PLASTICITY
Very Soft	< 500	(< 24)	Description
Soft	500 - 1000	(24 - 48)	Lean
Medium	1001 - 2000	(48 - 96)	Lean to Fat
Stiff	2001 - 4000	(96 - 192)	Fat
Very Stiff	4001 - 8000	(192 - 383)	
Hard	> 8001	(> 383)	

Cohesive Soils Consistency "N" value	
Very Soft	<2
Soft	2-4
Medium	4-8
Stiff (Firm)	8-15
Very Stiff (Very Firm)	15-30
Hard	>30

COHESIONLESS SOILS

RELATIVE DENSITY	"N" VALUE*
Very Loose	0 - 3
Loose	4 - 9
Medium Dense	10 - 29
Dense	30 - 49
Very Dense	≥ 50

BEDROCK PROPERTIES & DESCRIPTIONS

ROCK QUALITY DESIGNATION (RQD**)

DESCRIPTION OF ROCK QUALITY	RQD (%)
Very Poor	0 - 25
Poor	25 - 50
Fair	50 - 75
Good	75 - 90
Excellent	90 - 100

**RQD is defined as the total length of sound core pieces, 4 inches (102mm) or greater in length, expressed as a percentage of the total length cored. RQD provides an indication of the integrity of the rock mass and relative extent of seams and bedding planes.

DEGREE OF WEATHERING

Slightly Weathered	Slight decomposition of parent material in joints and seams.
Weathered	Well-developed and decomposed joints and seams.
Highly Weathered	Rock highly decomposed, may be extremely broken.

SOLUTION AND VOID CONDITIONS

Solid	Contains no voids.
Vuggy	Containing small pits or cavities < 1/2" (13mm).
Porous	Containing numerous voids which may be interconnected.
Cavernous	Containing cavities, sometimes quite large.

When classification of rock materials has been estimated from disturbed samples, core samples and petrographic analysis may reveal other rock types.

HARDNESS & DEGREE OF CEMENTATION

LIMESTONE	
Hard	Difficult to scratch with knife.
Moderately Hard	Can scratch with knife but not with fingernail.
Soft	Can be scratched with fingernail.
SHALE	
Hard	Can scratch with knife but not with fingernail.
Moderately Hard	Can be scratched with fingernail.
Soft	Can be molded easily with fingers.
SANDSTONE	
Well Cemented	Capable of scratching a knife blade.
Cemented	Can be scratched with knife.
Poorly Cemented	Can be broken apart easily with fingers.

BEDDING CHARACTERISTICS

TERM	THICKNESS (inches)	THICKNESS (mm)
Very Thick Bedded	> 36	> 915
Thick Bedded	12 - 36	305 - 915
Medium Bedded	4 - 12	102 - 305
Thin Bedded	1 - 4	25 - 102
Very Thin Bedded	0.4 - 1	10 - 25
Laminated	0.1 - 0.4	2.5 - 10
Thinly Laminated	< 0.1	< 2.5
Bedding Planes	Planes dividing the individual layers, beds or strata of rocks.	
Joint	Fracture in rock, generally more or less vertical or transverse to the bedding.	
Seam	Applies to bedding plane with an unspecified degree of weathering.	

BORHOLE LOG				BH-1		Sheet		1 OF 1															
Project No.				16027-01		Date		2/28/2016															
Project				Redlands Masjid		Drilling Rig		CME 45															
Client				Mr. Shakil Patel		Sampler		Cal Mod. And SPT															
Location				APN 0293-111-15-0000, Redlands, CA		Method		Hollow Stem															
Coordinate						Hammer Type		140 lb															
Notes						Surface Elev.																	
						Total Depth		15'															
Type/Symbol	Casing	Split Spoon	Ring Sampler	Cutting	Date	Time	Water Depth (ft)	Casing Size (in)	Casing Depth (ft)	Moisture (%)	Dry Density (pcf)	Test											
I.D.		S	R	C	2/28/2016		None																
O.D.																							
Length																							
Hammer Wt.																							
Hammer Fall																							
Depth Below Surface (ft)	Elevation (ft)	Soil Sample				Blows				VISUAL MATERIAL CLASSIFICATION AND REMARKS													
		Type	Number	Symbol	Depth	0-152.4 mm	152.4-304.8 mm	304.8-457.2 mm	N-Value					N60	(N1)60								
0																							
1																							
2																							
3		R		⚡	10	13	15	18															
4																							
5																							
6																							
7																							
8																							
9																							
10		S		█	2	2	3	5															
11																							
12																							
13																							
14		S		█	7	11	15	26															
15																							
16																							
17																							
18																							
19																							
20																							
21																							
22																							
23																							
24																							

The stratification lines represent the approximate boundary lines between soil and rock types. In-situ, the transition may be gradual.

Appendix C

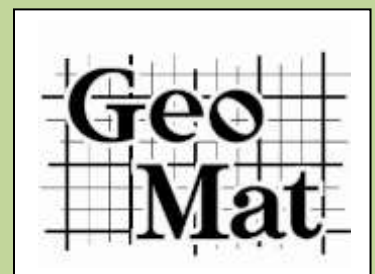

LABORATORY TEST RESULTS

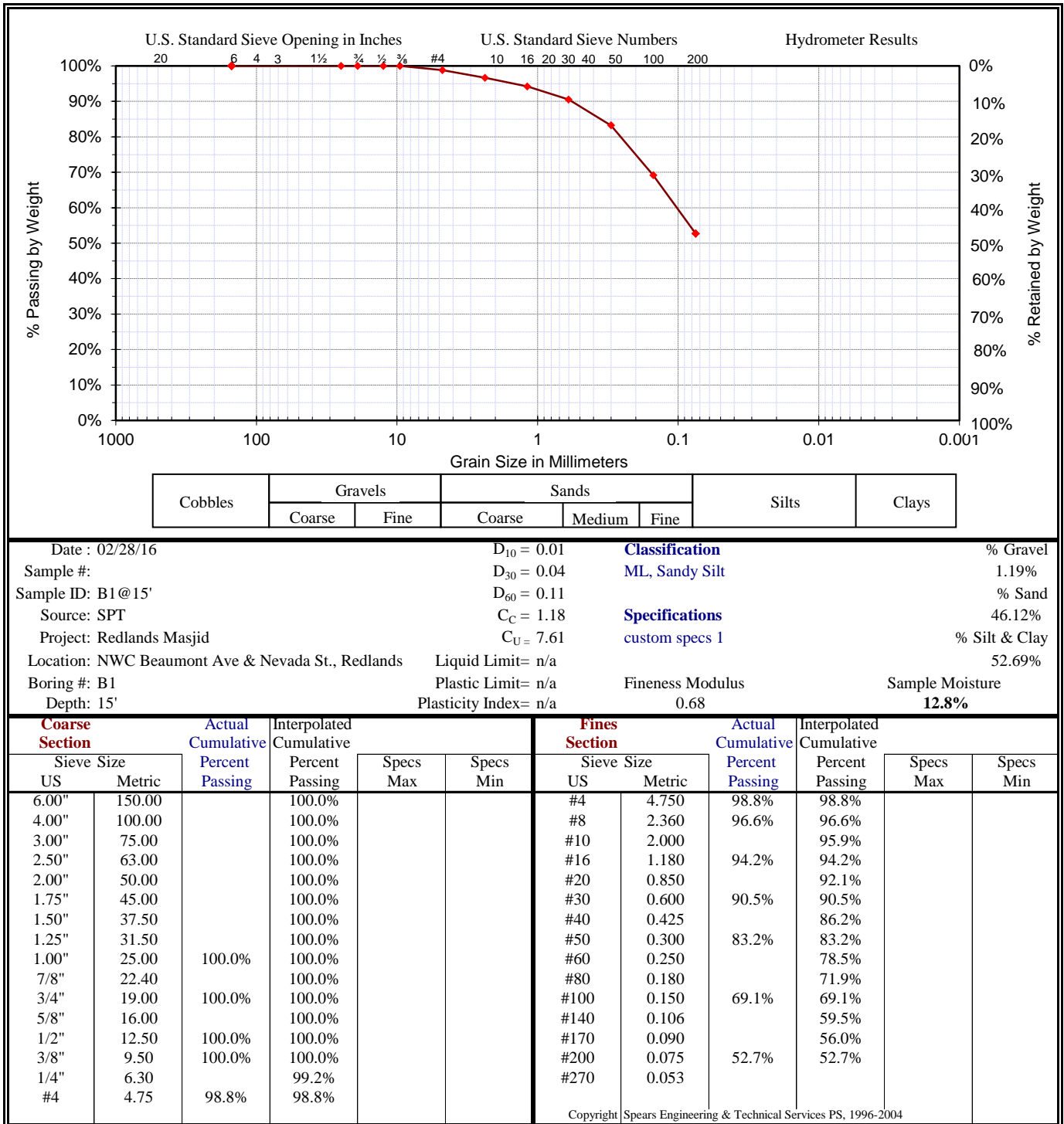

LABORATORY TEST RESULTS

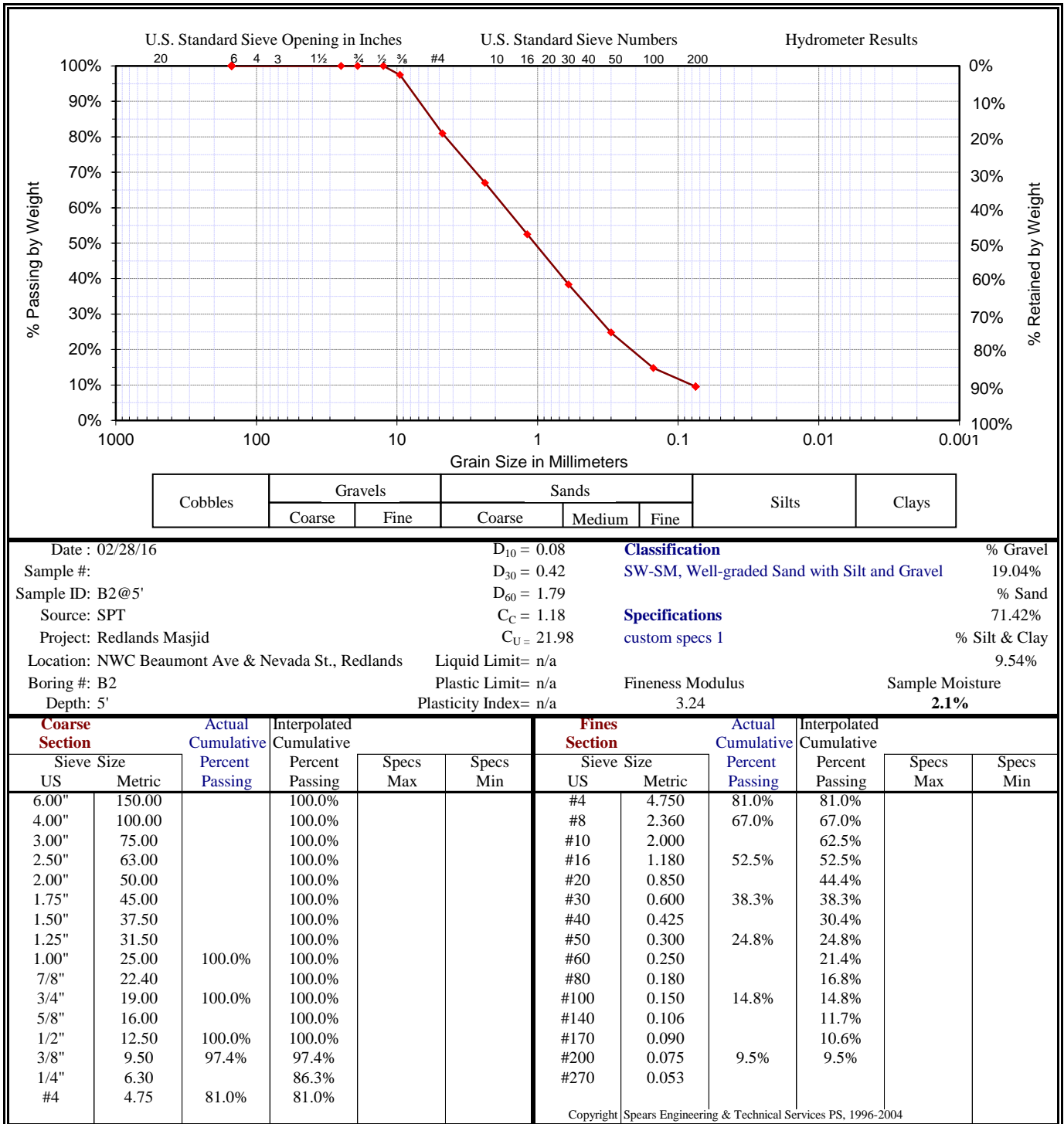

LABORATORY TEST RESULTS

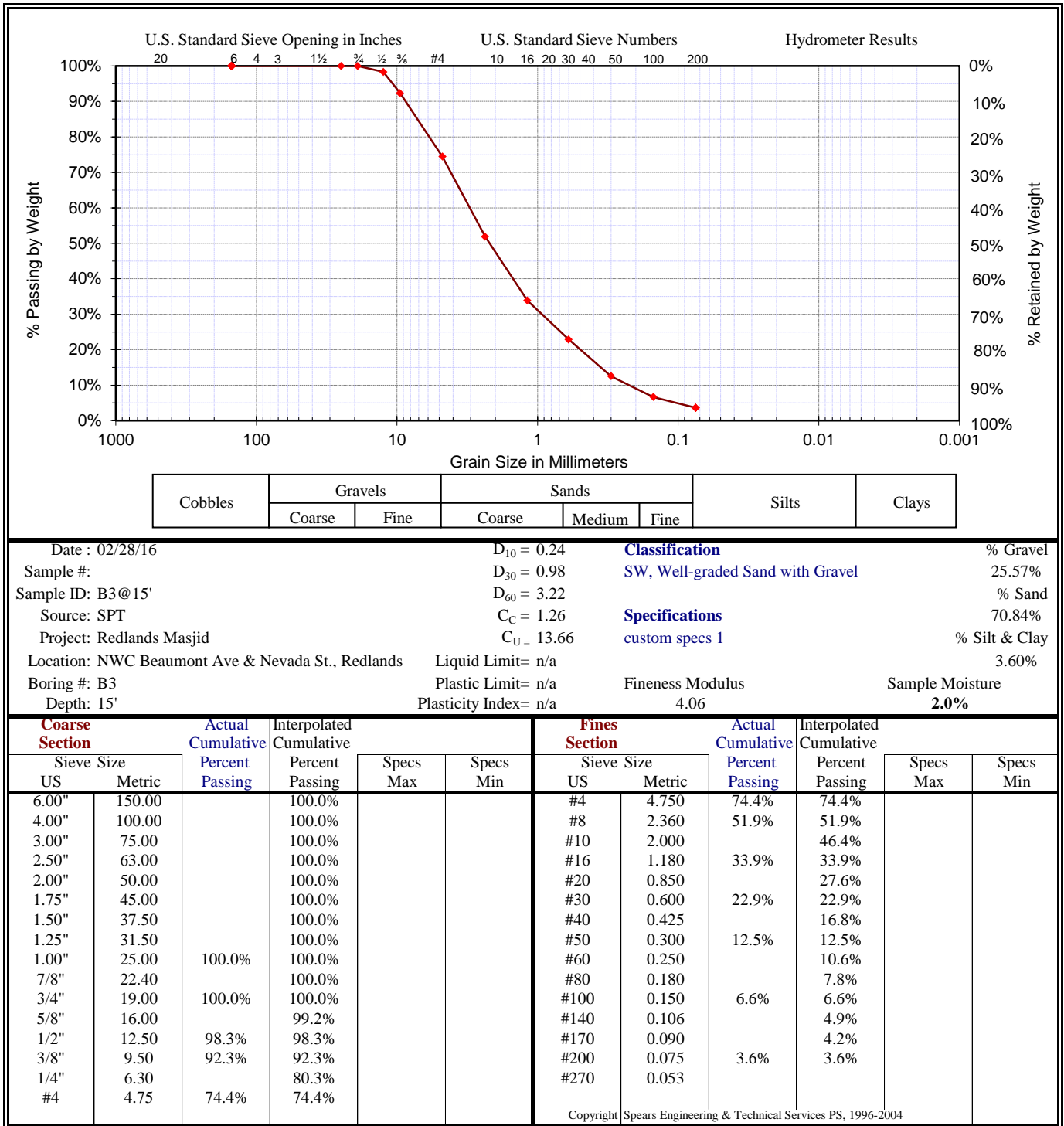

DIRECT SHEAR TEST RESULTS

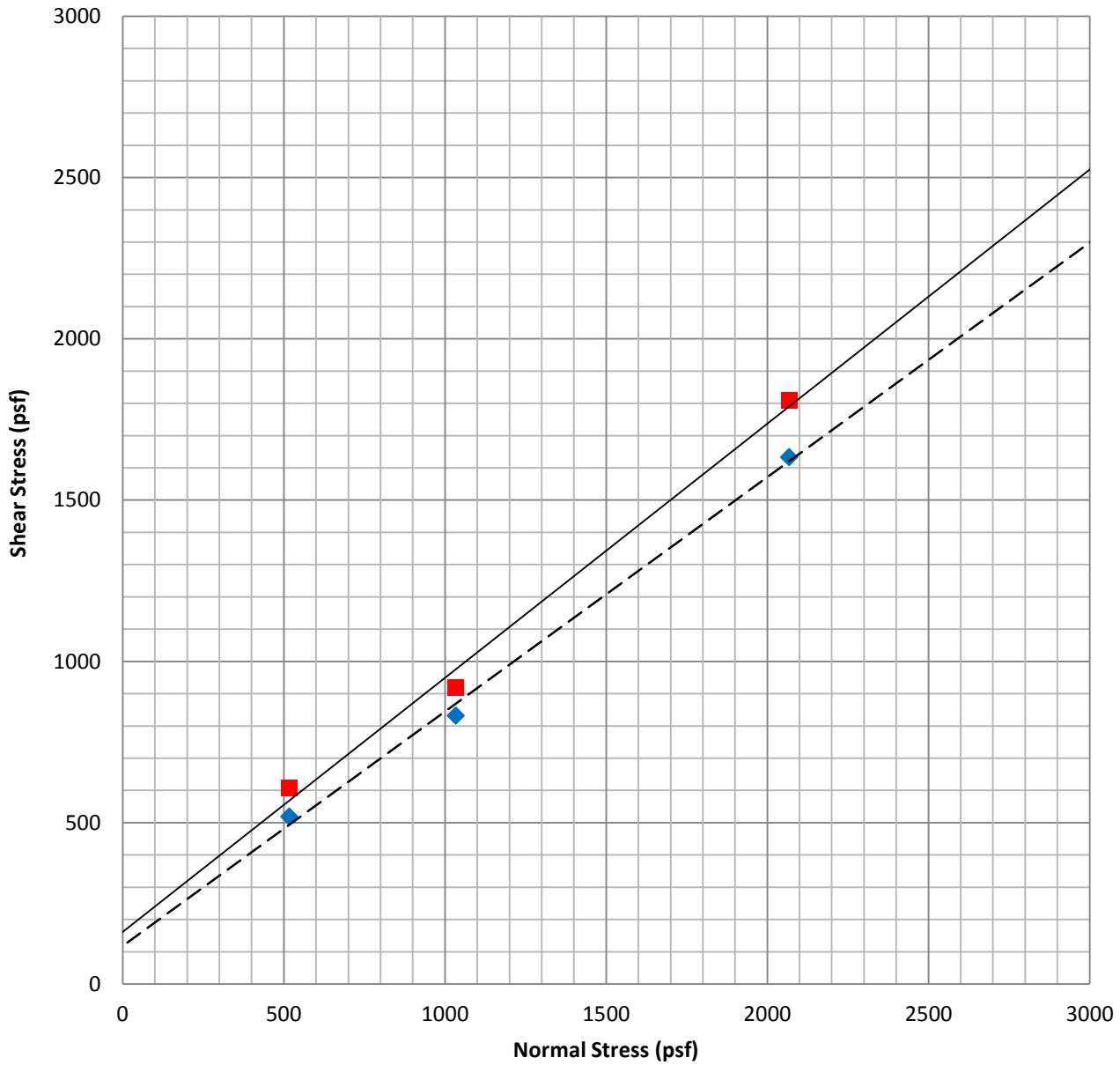

Sample	Symbol	Description	Soil Type [USCS]	Shear Strength	Friction Angle, ϕ [degrees]	Cohesion, c [psf]
B3 @ 5'	—■—	Silty Sand	SM	Peak	38.2	161
B3 @ 5'	--◆--	Silty Sand	SM	Ultimate	36.0	117

Sample Moisture [%]	Saturated Moisture [%]	Dry Unit Weight [pcf]
6.0	17.5	121.3
ASTM D-3080		





GeoMat Testing Laboratories, Inc.

Soil Engineering, Environmental Engineering, Materials Testing, Geology

SOLUBLE SULFATE AND CHLORIDE TEST RESULTS

Project Name	APN 0293-111-15-0000	Test Date	3/14/2016
Project No.	16027-01	Date Sampled	2/28/2016
Project Location	NWC Beaumont Ave and Nevada St., Redlands, CA	Sampled By	HMN
Location in Structure	Surface, Bulk	Sample Type	Bulk
Sampled Classification	SM	Tested By	AM

TESTING INFORMATION

Sample weight before drying	248.5
Sample weight after drying	235.5
Sample Weight Passing No. 10 Sieve	100 grams
Moisture	5.5%

Location	Mixing Ratio	Dilution Factor	Sulfate Reading (ppm)	Sulfate Content		Chloride Reading (ppm)	Chloride Content		pH
				(ppm)	(%)		(ppm)	(%)	
Bulk	3	1	<50	<150	<0.015				
				Average		Average		Average	

ACI 318-05 Table 4.3.1 Requirements for Concrete Exposed to Sulfate-Containing Solutions

Sulfate Exposure	Water-Soluble Sulfate (SO ₄) In Soil, % by Mass	Sulfate (SO ₄) In Water ppm	Cement Type	Maximum w/cm by Mass	Minimum Design Compressive Strength fc, MPa (psi)
Negligible	< 0.10	< 150	No Special Type	--	--
Moderate (see water)	0.10 to 0.20	150 to 1500	II IP(MS), IS(MS), P(MS), I(PM)(MS), I(SM)(MS)	0.50	28 (4000)
Severe	0.20 to 2.00	1500 to 10,000	V	0.45	31 (4500)
Very Severe	> 2.00	>10,000	V + pozz	0.45	31 (4500)

Caltrans classifies a site as corrosive to structural concrete as an area where soil and/or water contains >500pp chloride, >2000ppm sulfate, or has a pH <5.5. A minimum resistivity of less than 1000 ohm-cm indicates the potential for corrosive environment requiring testing for the above criteria.

The 2007 CBC Section 1904A references ACI 318 for material selection and mix design for reinforced concrete dependant on the onsite corrosion potential, soluble chloride content, and soluble sulfate content in soil

Comments: Sec 4.3 of ACI 318 (2005) Soil environment is detrimental to concrete if it has soluble sulfate >1000ppm and/or pH<5.5. Soil environment is corrosive to reinforcement and steel pipes if Chloride ion >500ppm or pH <4.0.

The information in this form is not intended for corrosion engineering design. If corrosion is critical, a corrosion specialist should be contacted to provide further recommendations.

Signature	Date
Print Name	Title

Appendix D

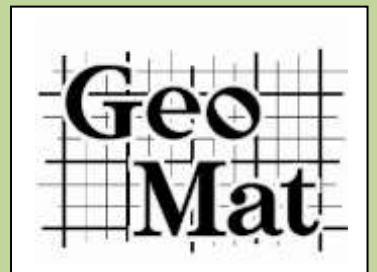

Design Maps Detailed Report

ASCE 7-10 Standard (34.0382°N, 117.2181°W)

Site Class D – “Stiff Soil”, Risk Category I/II/III

Section 11.4.1 – Mapped Acceleration Parameters

Note: Ground motion values provided below are for the direction of maximum horizontal spectral response acceleration. They have been converted from corresponding geometric mean ground motions computed by the USGS by applying factors of 1.1 (to obtain S_s) and 1.3 (to obtain S_1). Maps in the 2010 ASCE-7 Standard are provided for Site Class B. Adjustments for other Site Classes are made, as needed, in Section 11.4.3.

From [Figure 22-1](#) ^[1]

$S_s = 2.164 \text{ g}$

From [Figure 22-2](#) ^[2]

$S_1 = 0.981 \text{ g}$

Section 11.4.2 – Site Class

The authority having jurisdiction (not the USGS), site-specific geotechnical data, and/or the default has classified the site as Site Class D, based on the site soil properties in accordance with Chapter 20.

Table 20.3-1 Site Classification

Site Class	\bar{v}_s	\bar{N} or \bar{N}_{ch}	\bar{s}_u
A. Hard Rock	>5,000 ft/s	N/A	N/A
B. Rock	2,500 to 5,000 ft/s	N/A	N/A
C. Very dense soil and soft rock	1,200 to 2,500 ft/s	>50	>2,000 psf
D. Stiff Soil	600 to 1,200 ft/s	15 to 50	1,000 to 2,000 psf
E. Soft clay soil	<600 ft/s	<15	<1,000 psf
Any profile with more than 10 ft of soil having the characteristics:			
<ul style="list-style-type: none"> • Plasticity index $PI > 20$, • Moisture content $w \geq 40\%$, and • Undrained shear strength $\bar{s}_u < 500$ psf 			
F. Soils requiring site response analysis in accordance with Section 21.1	See Section 20.3.1		

For SI: 1ft/s = 0.3048 m/s 1lb/ft² = 0.0479 kN/m²

Section 11.4.3 — Site Coefficients and Risk-Targeted Maximum Considered Earthquake (MCE_R) Spectral Response Acceleration Parameters

Table 11.4-1: Site Coefficient F_a

Site Class	Mapped MCE_R Spectral Response Acceleration Parameter at Short Period				
	$S_s \leq 0.25$	$S_s = 0.50$	$S_s = 0.75$	$S_s = 1.00$	$S_s \geq 1.25$
A	0.8	0.8	0.8	0.8	0.8
B	1.0	1.0	1.0	1.0	1.0
C	1.2	1.2	1.1	1.0	1.0
D	1.6	1.4	1.2	1.1	1.0
E	2.5	1.7	1.2	0.9	0.9
F	See Section 11.4.7 of ASCE 7				

Note: Use straight-line interpolation for intermediate values of S_s

For Site Class = D and $S_s = 2.164$ g, $F_a = 1.000$

Table 11.4-2: Site Coefficient F_v

Site Class	Mapped MCE_R Spectral Response Acceleration Parameter at 1-s Period				
	$S_1 \leq 0.10$	$S_1 = 0.20$	$S_1 = 0.30$	$S_1 = 0.40$	$S_1 \geq 0.50$
A	0.8	0.8	0.8	0.8	0.8
B	1.0	1.0	1.0	1.0	1.0
C	1.7	1.6	1.5	1.4	1.3
D	2.4	2.0	1.8	1.6	1.5
E	3.5	3.2	2.8	2.4	2.4
F	See Section 11.4.7 of ASCE 7				

Note: Use straight-line interpolation for intermediate values of S_1

For Site Class = D and $S_1 = 0.981$ g, $F_v = 1.500$

Equation (11.4-1):

$$S_{MS} = F_a S_S = 1.000 \times 2.164 = 2.164 \text{ g}$$

Equation (11.4-2):

$$S_{M1} = F_v S_1 = 1.500 \times 0.981 = 1.471 \text{ g}$$

Section 11.4.4 — Design Spectral Acceleration Parameters

Equation (11.4-3):

$$S_{DS} = \frac{2}{3} S_{MS} = \frac{2}{3} \times 2.164 = 1.443 \text{ g}$$

Equation (11.4-4):

$$S_{D1} = \frac{2}{3} S_{M1} = \frac{2}{3} \times 1.471 = 0.981 \text{ g}$$

Section 11.4.5 — Design Response Spectrum

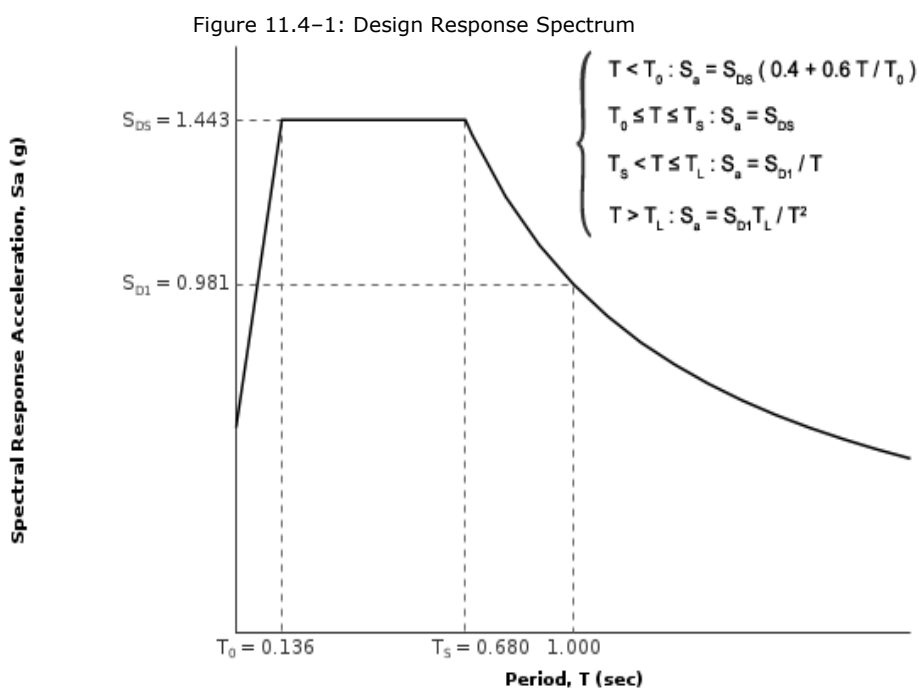
From [Figure 22-12](#) ^[3] $T_L = 8$ seconds

Section 11.4.6 — Risk-Targeted Maximum Considered Earthquake (MCE_R) Response Spectrum

The MCE_R Response Spectrum is determined by multiplying the design response spectrum above by 1.5.

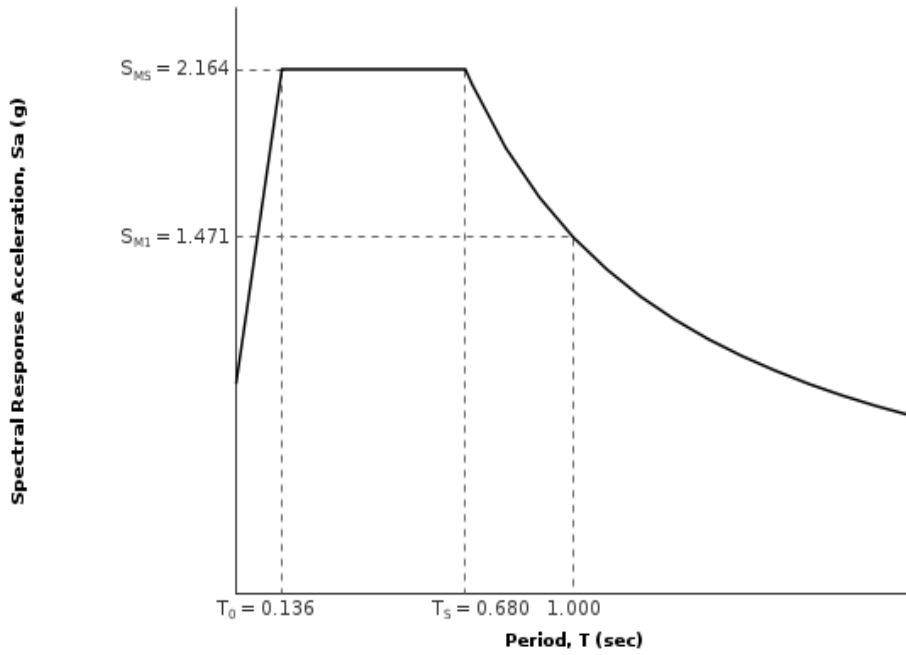

Section 11.8.3 — Additional Geotechnical Investigation Report Requirements for Seismic Design Categories D through F

From [Figure 22-7](#) ^[4]

$$PGA = 0.836$$

Equation (11.8-1):

$$PGA_M = F_{PGA}PGA = 1.000 \times 0.836 = 0.836 \text{ g}$$

Table 11.8-1: Site Coefficient F_{PGA}

Site Class	Mapped MCE Geometric Mean Peak Ground Acceleration, PGA				
	PGA ≤ 0.10	PGA = 0.20	PGA = 0.30	PGA = 0.40	PGA ≥ 0.50
A	0.8	0.8	0.8	0.8	0.8
B	1.0	1.0	1.0	1.0	1.0
C	1.2	1.2	1.1	1.0	1.0
D	1.6	1.4	1.2	1.1	1.0
E	2.5	1.7	1.2	0.9	0.9
F	See Section 11.4.7 of ASCE 7				

Note: Use straight-line interpolation for intermediate values of PGA

For Site Class = D and PGA = 0.836 g, $F_{PGA} = 1.000$

Section 21.2.1.1 — Method 1 (from Chapter 21 – Site-Specific Ground Motion Procedures for Seismic Design)

From [Figure 22-17](#) ^[5]

$$C_{RS} = 1.012$$

From [Figure 22-18](#) ^[6]

$$C_{R1} = 0.971$$

Section 11.6 — Seismic Design Category

Table 11.6-1 Seismic Design Category Based on Short Period Response Acceleration Parameter

VALUE OF S_{DS}	RISK CATEGORY		
	I or II	III	IV
$S_{DS} < 0.167g$	A	A	A
$0.167g \leq S_{DS} < 0.33g$	B	B	C
$0.33g \leq S_{DS} < 0.50g$	C	C	D
$0.50g \leq S_{DS}$	D	D	D

For Risk Category = I and $S_{DS} = 1.443 g$, Seismic Design Category = D

Table 11.6-2 Seismic Design Category Based on 1-S Period Response Acceleration Parameter

VALUE OF S_{D1}	RISK CATEGORY		
	I or II	III	IV
$S_{D1} < 0.067g$	A	A	A
$0.067g \leq S_{D1} < 0.133g$	B	B	C
$0.133g \leq S_{D1} < 0.20g$	C	C	D
$0.20g \leq S_{D1}$	D	D	D

For Risk Category = I and $S_{D1} = 0.981 g$, Seismic Design Category = D

Note: When S_1 is greater than or equal to 0.75g, the Seismic Design Category is **E** for buildings in Risk Categories I, II, and III, and **F** for those in Risk Category IV, irrespective of the above.

Seismic Design Category \equiv "the more severe design category in accordance with Table 11.6-1 or 11.6-2" = E

Note: See Section 11.6 for alternative approaches to calculating Seismic Design Category.

References

1. Figure 22-1: http://earthquake.usgs.gov/hazards/designmaps/downloads/pdfs/2010_ASCE-7_Figure_22-1.pdf
2. Figure 22-2: http://earthquake.usgs.gov/hazards/designmaps/downloads/pdfs/2010_ASCE-7_Figure_22-2.pdf
3. Figure 22-12: http://earthquake.usgs.gov/hazards/designmaps/downloads/pdfs/2010_ASCE-7_Figure_22-12.pdf
4. Figure 22-7: http://earthquake.usgs.gov/hazards/designmaps/downloads/pdfs/2010_ASCE-7_Figure_22-7.pdf
5. Figure 22-17: http://earthquake.usgs.gov/hazards/designmaps/downloads/pdfs/2010_ASCE-7_Figure_22-17.pdf
6. Figure 22-18: http://earthquake.usgs.gov/hazards/designmaps/downloads/pdfs/2010_ASCE-7_Figure_22-18.pdf

Appendix E

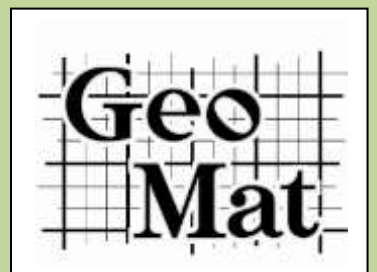

TABLE OF CONTENT

	Page
GENERAL	I
DEFINITION OF TERMS	I
OBLIGATIONS OF PARTIES	III
SITE PREPARATION	IV
SITE PROTECTION	IV
EXCAVATIONS	V
Unsuitable Materials	V
Cut Slopes.....	V
Pad Areas	V
COMPACTED FILL.....	VI
Placement	VI
Moisture	VII
Fill Material.....	VII
Fill Slopes.....	VIII
Off-Site Fill	VIII
DRAINAGE	IX
STAKING	IX
SLOPE MAINTENANCE.....	IX
Landscape Plants	IX
Irrigation	IX
Maintenance.....	IX
Repairs.....	X
TRENCH BACKFILL.....	X
STATUS OF GRADING	X

GENERAL

The guidelines contained herein and the standard details attached hereto represent this firm's standard recommendation for grading and other associated operations on construction projects. These guidelines should be considered a portion of the project specifications.

All plates attached hereto shall be considered as part of these guidelines.

The Contractor should not vary from these guidelines without prior recommendation by the Geotechnical Consultant and the approval of the Client or his authorized representative. Recommendation by the Geotechnical Consultant and/or Client should not be considered to preclude requirements for the approval by the controlling agency prior to the execution of any changes.

These Standard Grading Guidelines and Standard Details may be modified and/or superseded by recommendations contained in the text of the preliminary Geotechnical Report and/or subsequent reports.

If disputes arise out of the interpretation of these grading guidelines or standard details, the Geotechnical Consultant shall provide the governing interpretation.

DEFINITION OF TERMS

ALLUVIUM

Unconsolidated soil deposits resulting from flow of water, including sediments deposited in river beds, canyons, flood plains, lakes, fans and estuaries.

AS-GRADED (AS-BUILT): The surface and subsurface conditions at completion of grading.

BACKCUT: A temporary construction slope at the rear of earth retaining structures such as buttresses, shear keys, stabilization fills or retaining walls.

BACKDRAIN: Generally a pipe and gravel or similar drainage system placed behind earth retaining structures such as buttresses, stabilization fills, and retaining walls.

BEDROCK: Relatively undisturbed formational rock, more or less solid, either at the surface or beneath superficial deposits of soil.

BENCH: A relatively level step and near vertical rise excavated into sloping ground on which fill is to be placed.

BORROW (Import): Any fill material hauled to the project site from off-site areas.

BUTTRESS FILL: A fill mass, the configuration of which is designed by engineering calculations to retain slope conditions containing adverse geologic features. A buttress is generally specified by minimum key width and depth and by maximum backcut angle. A buttress normally contains a back-drainage system.

CIVIL ENGINEER: The Registered Civil Engineer or consulting firm responsible for preparation of the grading plans, surveying and verifying as-graded topographic conditions.

CLIENT: The Developer or his authorized representative who is chiefly in charge of the project. He shall have the responsibility of reviewing the findings and recommendations made by the Geotechnical Consultant and shall authorize the Contractor and/or other consultants to perform work and/or provide services.

COLLUVIUM: Generally loose deposits usually found near the base of slopes and brought there chiefly by gravity through slow continuous downhill creep (also see Slope Wash).

COMPACTION : Densification of man-placed fill by mechanical means.

CONTRACTOR – A person or company under contract or otherwise retained by the Client to perform demolition, grading and other site improvements.

DEBRIS: All products of clearing, grubbing, demolition, and contaminated soil materials unsuitable for reuse as compacted fill, and/or any other material so designated by the Geotechnical Consultant.

ENGINEERING GEOLOGIST: A Geologist holding a valid certificate of registration in the specialty of Engineering Geology.

ENGINEERED FILL: A fill of which the Geotechnical Consultant or his representative, during grading, has made sufficient tests to enable him to conclude that the fill has been placed in substantial compliance with the recommendations of the Geotechnical Consultant and the governing agency requirements.

EROSION: The wearing away of ground surface as a result of the movement of wind, water, and/or ice.

EXCAVATION: The mechanical removal of earth materials.

EXISTING GRADE: The ground surface configuration prior to grading.

FILL: Any deposits of soil, rock, soil-rock blends or other similar materials placed by man.

FINISH GRADE: The ground surface configuration at which time the surface elevations conform to the approved plan.

GEOFABRIC: Any engineering textile utilized in geotechnical applications including subgrade stabilization and filtering.

GEOLOGIST: A representative of the Geotechnical Consultant educated and trained in the field of geology.

GEOTECHNICAL CONSULTANT: The Geotechnical Engineering and Engineering Geology consulting firm retained to provide technical services for the project. For the purpose of these specifications, observations by the Geotechnical Consultant include observations by the Soil Engineer, Geotechnical Engineer, Engineering Geologist and those performed by persons employed by and responsible to the Geotechnical Consultants.

GEOTECHNICAL ENGINEER: A licensed Geotechnical Engineer or Civil Engineer who applies scientific methods, engineering principles and professional experience to the acquisition, interpretation and use of knowledge of materials of the earth's crust for the evaluation of engineering problems. Geotechnical Engineering encompasses many of the engineering aspects of soil mechanics, rock mechanics, geology, geophysics, hydrology and related sciences.

GRADING: Any operation consisting of excavation, filling or combinations thereof and associated operations.

LANDSIDE DEBRIS: Material, generally porous and of low density, produced from instability of natural or man-made slopes.

MAXIMUM DENSITY: Standard laboratory test for maximum dry unit weight. Unless otherwise specified, the maximum dry unit weight shall be determined in accordance with ASTM Method of Test D 1557-91.

OPTIMUM MOISTURE – Soil moisture content at the test maximum density.

RELATIVE COMPACTION: The degree of compaction (expressed as a percentage) of dry unit weight of a material as compared to the maximum dry unit weight of the material.

ROUGH GRADE: The ground surface configuration at which time the surface elevations approximately conform to the approved plan.

SITE: The particular parcel of land where grading is being performed.

SHEAR KEY: Similar to buttress, however, it is generally constructed by excavating a slot within a natural slope, in order to stabilize the upper portion of the slope without grading encroaching into the lower portion of the slope.

SLOPE: An inclined ground surface, the steepness of which is generally specified as a ration of horizontal:vertical (e.g., 2:1)

SLOPE WASH: Soil and/or rock material that has been transported down a slope by action of gravity assisted by runoff water not confined by channels (also see Colluvium).

SOIL: Naturally occurring deposits of sand, silt, clay, etc., or combinations thereof.

SOIL ENGINEER: Licensed Geotechnical Engineer or Civil Engineer experienced in soil mechanics (also see Geotechnical Engineer).

STABILIZATION FILL: A fill mass, the configuration of which is typically related to slope height and specified by the standards of practice for enhancing the stability of locally adverse conditions. A stabilization fill is normally specified by minimum key width and depth and by maximum backcut angle. A stabilization fill may or may not have a backdrainage system specified.

SUBDRAIN: Generally a pipe and gravel or similar drainage system placed beneath a fill in the alignment of canyons or formed drainage channels.

SLOUGH: Loose, non-compacted fill material generated during grading operations.

TAILINGS: Non-engineered fill which accumulates on or adjacent to equipment haul-roads.

TERRACE: Relatively level step constructed in the face of a graded slope surface for drainage control and maintenance purposes.

TOPSOIL: The presumable fertile upper zone of soil, which is usually darker in color and loose.

WINDROW: A string of large rocks buried within engineered fill in accordance with guidelines set forth by the Geotechnical Consultant.

OBLIGATIONS OF PARTIES

The Geotechnical Consultant should provide observation and testing services and should make evaluations in order to advise the Client on Geotechnical matters. The Geotechnical Consultant should report his findings and recommendations to the Client or his authorized representative.

The client should be chiefly responsible for all aspects of the project. He or his authorized representative has the responsibility of reviewing the findings and recommendations of the Geotechnical Consultant. He shall authorize or cause to have authorized the Contractor and/or other consultants to perform work and/or provide services.

During grading the Client or his authorized representative should remain on-site or should remain reasonably accessible to all concerned parties in order to make decisions necessary to maintain the flow of the project.

The Contractor should be responsible for the safety of the project and satisfactory completion of all grading and other associated operations on construction projects, including but not limited to, earthwork in accordance with the project plans, specifications and controlling agency requirements. During grading, the Contractor or his authorized representative should remain on-site. Overnight and on days off, the Contractor should remain accessible.

SITE PREPARATION

The Client, prior to any site preparation or grading, should arrange and attend a meeting among the Grading Contractor, the Design Engineer, the Geotechnical Consultant, representatives of the appropriate governing authorities as well as any other concerned parties. All parties should be given at least 48 hours notice.

Clearing and grubbing should consist of the removal of vegetation such as brush, grass, woods, stumps, trees, roots of trees and otherwise deleterious natural materials from the areas to be graded. Clearing and grubbing should extend to the outside of all proposed excavation and fill areas.

Demolition should include removal of buildings, structures, foundations, reservoirs, utilities (including underground pipelines, septic tanks, leach fields, seepage pits, cisterns, mining shafts, tunnels, etc.) and man-made surface and subsurface improvements from the areas to be graded. Demolition of utilities should include proper capping and/or re-routing pipelines at the project perimeter and cutoff and capping of wells in accordance with the requirements of the governing authorities and the recommendations of the Geotechnical Consultant at the time of the demolition.

Trees, plants or man-made improvements not planned to be removed or demolished should be protected by the Contractor from damage or injury.

Debris generated during clearing, grubbing and/or demolition operations should be wasted from areas to be graded and disposed off-site. Clearing, grubbing and demolition operations should be performed under the observation of the Geotechnical Consultant.

The Client or Contractor should obtain the required approvals for the controlling authorities for the project prior, during and/or after demolition, site preparation and removals, etc. The appropriate approvals should be obtained prior to proceeding with grading operations.

SITE PROTECTION

Protection of the site during the period of grading should be the responsibility of the Contractor. Unless other provisions are made in writing and agreed upon among the concerned parties, completion of a portion of the project should not be considered to preclude that portion or adjacent areas from the requirements for site protection until such time as the entire project is complete as identified by the Geotechnical Consultant, the Client and the regulating agencies.

The Contractor should be responsible for the stability of all temporary excavations. Recommendations by the Geotechnical Consultant pertaining to temporary excavations (e.g., backcuts) are made in consideration of stability of the completed project and therefore, should not be considered to preclude the responsibilities of the Contractor. Recommendations by the Geotechnical Consultant should not be considered to preclude more restrictive requirements by the regulating agencies.

Precautions should be taken during the performance of site clearing, excavations and grading to protect the work site from flooding, ponding, or inundation by poor or improper surface drainage. Temporary provisions should be made during the rainy season to adequately direct surface drainage away from and off the work site. Where low areas can not be avoided, pumps should be kept on hand to continually remove water during periods of rainfall.

During periods of rainfall, plastic sheeting should be kept reasonably accessible to prevent unprotected slopes from becoming saturated. Where necessary during periods of rainfall, the Contractor should install check-dams de-silting basins, rip-rap, sandbags or other devices or methods necessary to control erosion and provide safe conditions.

During periods of rainfall, the Geotechnical Consultant should be kept informed by the Contractor as to the nature of remedial or preventative work being performed (e.g., pumping, placement of sandbags or plastic sheeting, other labor, dozing, etc.).

Following periods of rainfall, the Contractor should contact the Geotechnical Consultant and arrange a walk-over of the site in order to visually assess rain related damage. The Geotechnical Consultant may also recommend excavations and testing in order to aid in his assessments. At the request of the Geotechnical Consultant, the Contractor shall make excavations in order to evaluate the extent of rain related damage.

Rain-related damage should be considered to include, but may not be limited to, erosion, silting, saturation, swelling, structural distress and other adverse conditions identified by the Geotechnical Consultant. Soil adversely affected should be classified as Unsuitable Materials and should be subject to overexcavation and replaced with compacted fill or other remedial grading as recommended by the Geotechnical Consultant.

Relatively level areas, where saturated soils and/or erosion gullies exist to depths greater than 1 foot, should be overexcavated to unaffected, competent material. Where less than 1 foot in depth, unsuitable materials may be processed in-place to achieve near optimum moisture conditions, then thoroughly recompacted in accordance with the applicable specifications. If the desired results are not achieved, the affected materials should be overexcavated then replaced in accordance with the applicable specifications.

In slope areas, where saturated soil and/or erosion gullies exist to depths of greater than 1 foot, should be over-excavated to unaffected, competent material. Where affected materials exist to depths of 1 foot or less below proposed finished grade, remedial grading by moisture conditioning in-place, followed by thorough recompaction in accordance with the applicable grading guidelines herein may be attempted. If the desired results are not achieved, all affected materials should be overexcavated and replaced as compacted fill in accordance with the slope repair recommendations herein. As field conditions dictate, other slope repair procedures may be recommended by the Geotechnical Consultant.

EXCAVATIONS

UNSUITABLE MATERIALS:

Materials which are unsuitable should be excavated under observation and recommendations of the Geotechnical Consultant. Unsuitable materials include, but may not be limited to dry, loose, soft, wet, organic compressible natural soils and fractured, weathered, soft, bedrock and nonengineered or otherwise deleterious fill materials.

Materials identified by the Geotechnical Consultant as unsatisfactory due to its moisture conditions should be overexcavated, watered or dried, as needed, and thoroughly blended to uniform near optimum moisture condition (per Moisture guidelines presented herein) prior to placement as compacted fill.

CUT SLOPES:

Unless otherwise recommended by the Geotechnical Consultant and approved by the regulating agencies, permanent cut slopes should not be steeper than 2:1 (horizontal:vertical).

If excavations for cut slopes expose loose, cohesionless, significantly fractured or otherwise suitable material, overexcavation and replacement of the unsuitable materials with a compacted stabilization fill should be accomplished as recommended by the Geotechnical Consultant. Unless otherwise specified by the Geotechnical Consultant, stabilization fill construction should conform to the requirements of the Standard Details.

The Geotechnical Consultant should review cut slopes during excavation. The Geotechnical Consultant should be notified by the contractor prior to beginning slope excavations.

If during the course of grading, adverse or potentially adverse geotechnical conditions are encountered which were not anticipated in the preliminary report, the Geotechnical Consultant should explore, analyze and make recommendations to treat these problems.

When cuts slopes are made in the direction of the prevailing drainage, a non-erodible diversion swale (brow ditch) should be provided at the top-of-cut.

PAD AREAS:

All lot pad areas, including side yard terraces, above stabilization fills or buttresses should be over-excavated to provide for a minimum of 3-feet (refer to Standard Details) of compacted fill over the entire pad area. Pad areas with both fill and cut materials exposed and pad areas containing both very shallow (less than 3-feet) and deeper fill should be over- thickness (refer to Standard Details).

Cut areas exposing significantly varying material types should also be overexcavated to provide for at least a 3-foot thick compacted fill blanket. Geotechnical conditions may require greater depth of overexcavation. The actual depth should be delineated by the Geotechnical Consultant during grading.

For pad areas created above cut or natural slopes, positive drainage should be established away from the top-of-slope. This may be accomplished utilizing a berm and/or an appropriate pad gradient. A gradient in soil areas away from the top-of-slope of 2 percent or greater is recommended.

COMPACTED FILL

All fill materials should be compacted as specified below or by other methods specifically recommended by the Geotechnical Consultant. Unless otherwise specified, the minimum degree of compaction (relative compaction) should be 90 percent of the laboratory maximum density.

PLACEMENT

Prior to placement of compacted fill, the Contractor should request a review by the Geotechnical Consultant of the exposed ground surface. Unless otherwise recommended, the exposed ground surface should then be scarified (6-inches minimum), watered or dried as needed, thoroughly blended to achieve near optimum moisture conditions, then thoroughly compacted to a minimum of 90 percent of the maximum density. The review by the Geotechnical Consultants should not be considered to preclude requirements of inspection and approval by the governing agency.

Compacted fill should be placed in thin horizontal lifts not exceeding 8-inches in loose thickness prior to compaction. Each lift should be watered or dried as needed, thoroughly blended to achieve near optimum moisture conditions then thoroughly compacted by mechanical methods to a minimum of 90 percent of laboratory maximum dry density. Each lift should be treated in a like manner until the desired finished grades are achieved.

The Contractor should have suitable and sufficient mechanical compaction equipment and watering apparatus on the job site to handle the amount of fill being placed in consideration of moisture retention properties of the materials. If necessary, excavation equipment should be "shut down" temporarily in order to permit proper compaction of fills. Earth moving equipment should only be considered a supplement and not substituted for conventional compaction equipment.

When placing fill in horizontal lifts adjacent to areas sloping steeper than 5:1 (horizontal:vertical), horizontal keys and vertical benches should be excavated into the adjacent slope area. Keying and benching should be sufficient to provide at least 6-foot wide benches and minimum of 4-feet of vertical bench height within the firm natural ground, firm bedrock or engineered compacted fill. No compacted fill should be placed in an area subsequent to keying and benching until the area has been reviewed by the Geotechnical Consultant. Material generated by the benching operation should be moved sufficiently away from the bench area to allow for the recommended review of the horizontal bench prior to placement of fill. Typical keying and benching details have been included within the accompanying Standard Details.

Within a single fill area where grading procedures dictate two or more separate fills, temporary slopes (false slopes) may be created. When placing fill adjacent to a false slope, benching should be conducted in the same manner as above described. At least a 3-foot vertical bench should be established within the firm core of adjacent approved compacted fill prior to placement of additional fill. Benching should proceed in at least 3-foot vertical increments until the desired finished grades are achieved.

Fill should be tested for compliance with the recommended relative compaction and moisture conditions. Field density testing should conform to ASTM Method of Testing D 1556-64, D 2922-78 and/or D2937-71. Tests should be provided for about every 2 vertical feet or 1,000 cubic yards of fill placed. Actual test intervals may vary as field conditions dictate. Fill found not to be in conformance with the grading recommendations should be removed or otherwise handled as recommended by the Geotechnical Consultant.

The Contractor should assist the Geotechnical Consultant and/or his representative by digging test pits for removal determinations and/or for testing compacted fill.

As recommended by the Geotechnical Consultant, the Contractor should "shutdown" or remove any grading equipment from an area being tested.

The Geotechnical Consultant should maintain a plan with estimated locations of field tests. Unless the client provides for actual surveying of test locations, by the Geotechnical Consultant should only be considered rough estimates and should not be utilized for the purpose of preparing cross sections showing test locations or in any case for the purpose of after-the-fact evaluating of the sequence of fill placement.

MOISTURE

For field testing purposes, “near optimum” moisture will vary with material type and other factors including compaction procedures. “Near optimum” may be specifically recommended in Preliminary Investigation Reports and/or may be evaluated during grading.

Prior to placement of additional compacted fill following an overnight or other grading delay, the exposed surface of previously compacted fill should be processed by scarification, watered or dried as needed, thoroughly blended to near-optimum moisture conditions, then recompacted to a minimum of 90 percent of laboratory maximum dry density. Where wet or other dry or other unsuitable materials exist to depths of greater than one foot, the unsuitable materials should be overexcavated.

Following a period of flooding, rainfall or overwatering by other means, no additional fill should be placed until damage assessments have been made and remedial grading performed as described herein.

FILL MATERIAL

Excavated on-site materials which are acceptable to the Geotechnical Consultant may be utilized as compacted fill, provided trash, vegetation and other deleterious materials are removed prior to placement.

Where import materials are required for use on-site, the Geotechnical Consultant should be notified at least 72 hours in advance of importing, in order to sample and test materials from proposed borrow sites. No import materials should be delivered for use on-site without prior sampling and testing by Geotechnical Consultant.

Where oversized rock or similar irreducible material is generated during grading, it is recommended, where practical, to waste such material off-site or on-site in areas designated as “nonstructural rock disposal areas”. Rock placed in disposal areas should be placed with sufficient fines to fill voids. The rock should be compacted in lifts to an unyielding condition. The disposal area should be covered with at least 3-feet of compacted fill, which is free of oversized material. The upper 3-feet should be placed in accordance with the guidelines for compacted fill herein.

Rocks 3 inches in maximum dimension and smaller may be utilized within the compacted fill, provided they are placed in such a manner that nesting of the rock is avoided. Fill should be placed and thoroughly compacted over and around all rock. The amount of rock should not exceed 40 percent by dry weight passing the $\frac{3}{4}$ -inch sieve size. The 3-inch and 40 percent recommendations herein may vary as field conditions dictate.

During the course of grading operations, rocks or similar irreducible materials greater than 3-inch maximum dimension (oversized material) may be generated. These rocks should not be placed within the compacted fill unless placed as recommended by the Geotechnical Consultant.

Where rocks or similar irreducible materials of greater than 3-inches but less than 4-feet of maximum dimension are generated during grading, or otherwise desired to be placed within an engineered fill, special handling in accordance with the accompanying Standard Details is recommended. Rocks greater than 4 feet should be broken down or disposed off-site. Rocks up to 4-feet maximum dimension should be placed below the upper 10-feet of any fill and should not be closer than 20-feet to any slope face. These recommendations could vary as locations of improvements dictate. Where practical, oversized material should not be placed below areas where structures of deep utilities are proposed.

Oversized material should be placed in windrows on a clean, overexcavated or unyielding compacted fill or firm natural ground surface. Select native or imported granular soil (S.E. 30 or higher) should be placed and thoroughly flooded over and around all windrowed rock, such that voids are filled. Windrows of oversized material should be staggered so that successive strata of oversized material are not in the same vertical plane.

It may be possible to dispose of individual larger rock as field conditions dictate and as recommended by the Geotechnical Consultant at time of placement.

Material that is considered unsuitable by the Geotechnical Consultant should not be utilized in the compacted fill.

During grading operations, placing and mixing the materials from the cut and/or borrow areas may result in soil mixtures which possess unique physical properties. Testing may be required of samples obtained directly from the fill areas in order to verify conformance with the specifications. Processing of these additional samples may take two or more working days. The Contractor may elect to move the operation to other areas within the project, or may continue placing compacted fill pending laboratory and field test results. Should he elect the second alternative, fill placed is done so at the Contractor’s risk.

Any fill placed in areas not previously reviewed and evaluated by the Geotechnical Consultant, and/or in other areas, without prior notification to the Geotechnical Consultant may require removal and recompaction at the Contractor's expense. Determination of overexcavations should be made upon review of field conditions by the Geotechnical Consultant.

FILL SLOPES

Unless otherwise recommended by the Geotechnical Consultant and approved by the regulating agencies, permanent fill slopes should not be steeper than 2:1 (horizontal to vertical).

Except as specifically recommended otherwise or as otherwise provided for in these grading guidelines (Reference Fill Materials), compacted fill slopes should be overbuilt and cut back to grade, exposing the firm, compacted fill inner core. The actual amount of overbuilding may vary as field conditions dictate. If the desired results are not achieved, the existing slopes should be overexcavated and reconstructed under the guidelines of the Geotechnical Consultant. The degree of overbuilding shall be increased until the desired compacted slope surface condition is achieved. Care should be taken by the Contractor to provide thorough mechanical compaction to the outer edge of the overbuilt slope surface.

Although no construction procedure produces a slope free from risk of future movement, overfilling and cutting back of slope to a compacted inner core is, given no other constraints, the most desirable procedure. Other constraints, however, must often be considered. These constraints may include property line situations, access, the critical nature of the development, and cost. Where such constraints are identified, slope face compaction may be attempted by conventional construction procedures including backrolling techniques upon specific recommendations by the Geotechnical Consultant.

As a second best alternative for slopes of 2:1 (horizontal to vertical) or flatter, slope construction may be attempted as outlined herein. Fill placement should proceed in thin lifts, (i.e., 6 to 8 inch loose thickness). Each lift should be moisture conditioned and thoroughly compacted. The desired moisture condition should be maintained and/or reestablished, where necessary, during the period between successive lifts. Selected lifts should be tested to ascertain that desired compaction is being achieved. Care should be taken to extend compactive effort to the outer edge of the slope. Each lift should extend horizontally to the desired finished slope surface or more as needed to ultimately establish desired grades. Grade during construction should not be allowed to roll off at the edge of the slope. It may be helpful to elevate slightly the outer edge of the slope. Slough resulting from the placement of individual lifts should not be allowed to drift down over previous lifts. At intervals not exceeding 4-feet in vertical slope height or the capability of available equipment, whichever is less, fill slopes should be thoroughly backrolled utilizing a conventional sheepfoot-type roller. Care should be taken to maintain the desired moisture conditions and/or reestablishing same as needed prior to backrolling. Upon achieving final grade, the slopes should again be moisture conditioned and thoroughly backrolled. The use of a side-boom roller will probably be necessary and vibratory methods are strongly recommended. Without delay, so as to avoid (if possible) further moisture conditioning, the slopes should then be grid-rolled to achieve a relatively smooth surface and uniformly compact condition.

In order to monitor slope construction procedures, moisture and density tests will be taken at regular intervals. Failure to achieve the desired results will likely result in a recommendation by the Geotechnical Consultant to overexcavate the slope surfaces followed by reconstruction of the slopes utilizing overfilling and cutting back procedures and/or further attempt at the conventional backrolling approach. Other recommendations may also be provided which would be commensurate with field conditions.

Where placement of fill above a natural slope or above a cut slope is proposed, the fill slope configuration as presented in the accompanying standard Details should be adopted.

For pad areas above fill slopes, positive drainage should be established away from the top-of-slope. This may be accomplished utilizing a berm and pad gradients of at least 2-percent in soil area.

OFF-SITE FILL

Off-site fill should be treated in the same manner as recommended in these specifications for site preparation, excavation, drains, compaction, etc.

Off-site canyon fill should be placed in preparation for future additional fill, as shown in the accompanying Standard Details.

Off-site fill subdrains temporarily terminated (up canyon) should be surveyed for future relocation and connection.

DRAINAGE

Canyon sub-drain systems specified by the Geotechnical Consultant should be installed in accordance with the Standard Details.

Typical sub-drains for compacted fill buttresses, slope stabilization or sidehill masses, should be installed in accordance with the specifications of the accompanying Standard Details.

Roof, pad and slope drainage should be directed away from slopes and areas of structures to suitable disposal areas via non-erodible devices (i.e., gutters, downspouts, concrete swales).

For drainage over soil areas immediately away from structures (i.e., within 4-feet), a minimum of 4 percent gradient should be maintained. Pad drainage of at least 2 percent should be maintained over soil areas. Pad drainage may be reduced to at least 1 percent for projects where no slopes exist, either natural or man-made, or greater than 10-feet in height and where no slopes are planned, either natural or man-made, steeper than 2:1 (horizontal to vertical slope ratio).

Drainage patterns established at the time of fine grading should be maintained throughout the life of the project. Property owners should be made aware that altering drainage patterns can be detrimental to slope stability and foundation performance.

STAKING

In all fill areas, the fill should be compacted prior to the placement of the stakes. This particularly is important on fill slopes. Slope stakes should not be placed until the slope is thoroughly compacted (backrolled). If stakes must be placed prior to the completion of compaction procedures, it must be recognized that they will be removed and/or demolished at such time as compaction procedures resume.

In order to allow for remedial grading operations, which could include overexcavations or slope stabilization, appropriate staking offsets should be provided. For finished slope and stabilization backcut areas, we recommend at least 10-foot setback from proposed toes and tops-of-cut.

SLOPE MAINTENANCE LANDSCAPE PLANTS

In order to enhance superficial slope stability, slope planting should be accomplished at the completion of grading. Slope planting should consist of deep-rooting vegetation requiring little watering. Plants native to the Southern California area and plants relative to native plants are generally desirable. Plants native to other semiarid and arid areas may also be appropriate. A Landscape Architect would be the best party to consult regarding actual types of plants and planting configuration.

IRRIGATION

Irrigation pipes should be anchored to slope faces, not placed in trenches excavated into slope faces.

Slope irrigation should be minimized. If automatic timing devices are utilized on irrigation systems, provisions should be made for interrupting normal irrigation during periods of rainfall.

Though not a requirement, consideration should be given to the installation of near-surface moisture monitoring control devices. Such devices can aid in the maintenance of relatively uniform and reasonably constant moisture conditions.

Property owners should be made aware that overwatering of slopes is detrimental to slope stability.

MAINTENANCE

Periodic inspections of landscaped slope areas should be planned and appropriate measures should be taken to control weeds and enhance growth of the landscape plants. Some areas may require occasional replanting and/or reseeding.

Terrace drains and downdrains should be periodically inspected and maintained free of debris. Damage to drainage improvements should be repaired immediately.

Property owners should be made aware that burrowing animals can be detrimental to slope stability. A preventative program should be established to control burrowing animals.

As a precautionary measure, plastic sheeting should be readily available, or kept on hand, to protect all slope areas from saturation by periods of heavy or prolonged rainfall. This measure is strongly recommended, beginning with the period of time prior to landscape planting.

REPAIRS

If slope failures occur, the Geotechnical Consultant should be contacted for a field review of site conditions and development of recommendations for evaluation and repair.

If slope failure occurs as a result of exposure to periods of heavy rainfall, the failure areas and currently unaffected areas should be covered with plastic sheeting to protect against additional saturation.

In the accompanying Standard Details, appropriate repair procedures are illustrated for superficial slope failures (i.e., occurring typically within the outer 1 foot to 3 feet of a slope face).

TRENCH BACKFILL

Utility trench backfill should, unless otherwise recommended, be compacted by mechanical means. Unless otherwise recommended, the degree of compaction should be a minimum of 95 percent of the laboratory maximum density.

Approved granular material (sand equivalent greater than 30) should be used to bed and backfill utilities to a depth of at least 1 foot over the pipe. This backfill should be uniformly watered, compacted and/or wheel-rolled from the surface to a firm condition for pipe support.

The remainder of the backfill shall be typical on-site soil or imported soil which should be placed in lifts not exceeding 8 inches in thickness, watered or aerated to at least 3 percent above the optimum moisture content, and mechanically compacted to at least 95 percent of maximum dry density (based on ASTM D1557).

Backfill of exterior and interior trenches extending below a 1:1 projection from the outer edge of foundations should be mechanically compacted to a minimum of 95 percent of the laboratory maximum density.

Within slab areas, but outside the influence of foundations, trenches up to 1 foot wide and 2 feet deep may be backfilled with sand and consolidated by uniformly watering or by mechanical means. If on-site materials are utilized, they should be wheel-rolled, tamped or otherwise compacted to a firm condition. For minor interior trenches, density testing may be deleted or spot testing may be elected if deemed necessary, based on review of back-fill operations during construction.

If utility contractors indicate that it is undesirable to use compaction equipment in close proximity to a buried conduit, the Contractor may elect the utilization of light weight compaction equipment and/or shading of the conduit with clean, granular material, which should be thoroughly jetted in-place above the conduit, prior to initiating mechanical compaction procedures. Other methods of utility trench compaction may also be appropriate, upon review by the Geotechnical Consultant at the time of construction.

In cases where clean granular materials are proposed for use in lieu of native materials or where flooding or jetting is proposed, the procedures should be considered subject to review by the Geotechnical Consultant.

Clean Granular backfill and/or bedding are not recommended in slope areas unless provisions are made for a drainage system to mitigate the potential build-up of seepage forces.

STATUS OF GRADING

Prior to proceeding with any grading operation, the Geotechnical Consultant should be notified at least two working days in advance in order to schedule the necessary observation and testing services.

Prior to any significant expansion of cut back in the grading operation, the Geotechnical Consultant should be provided with adequate notice (i.e., two days) in order to make appropriate adjustments in observation and testing services.

Following completion of grading operations and/or between phases of a grading operation, the Geotechnical Consultant should be provided with at least two working days notice in advance of commencement of additional grading operations.

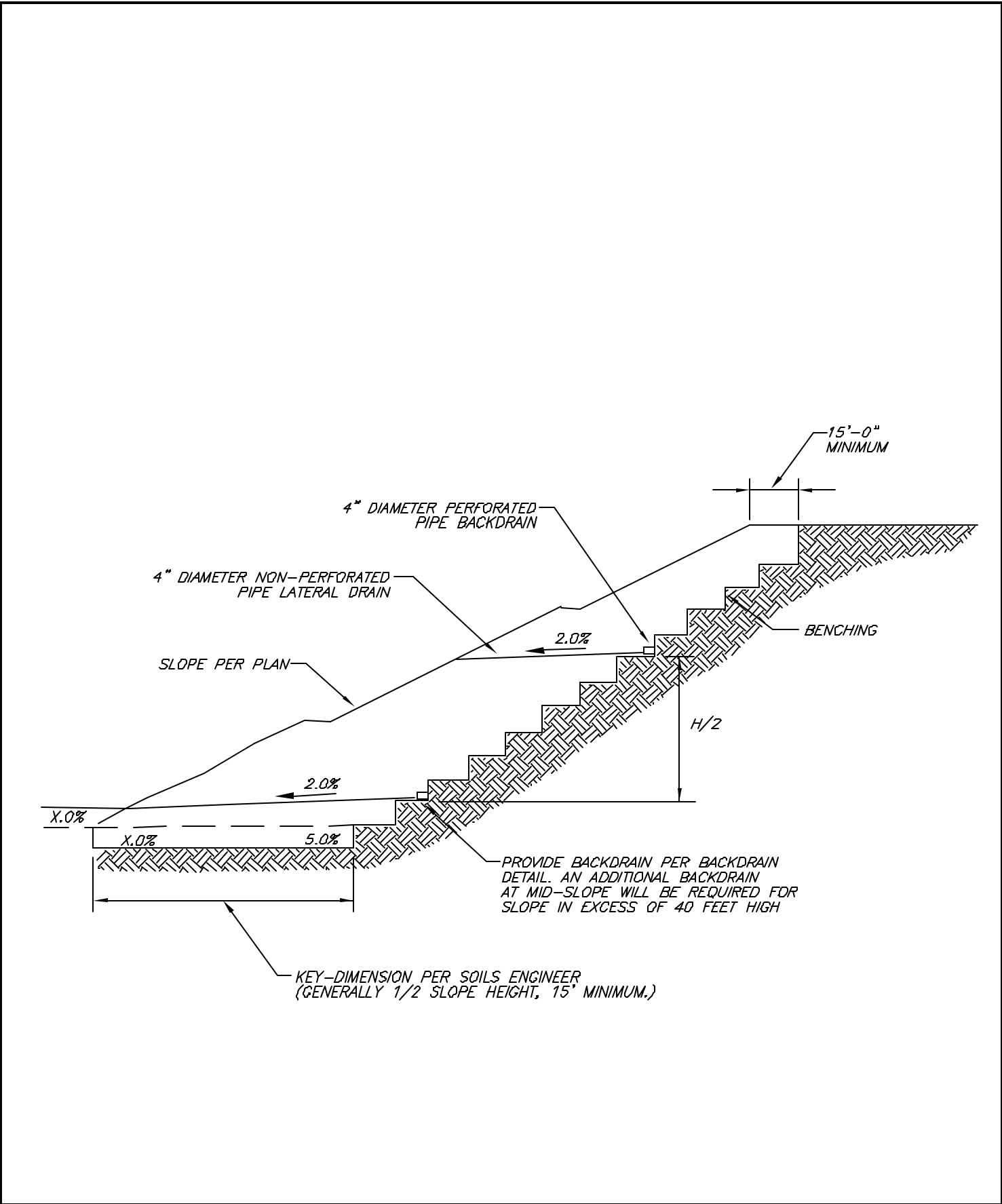

**TYPICAL STABILIZATION
FILL DETAIL**

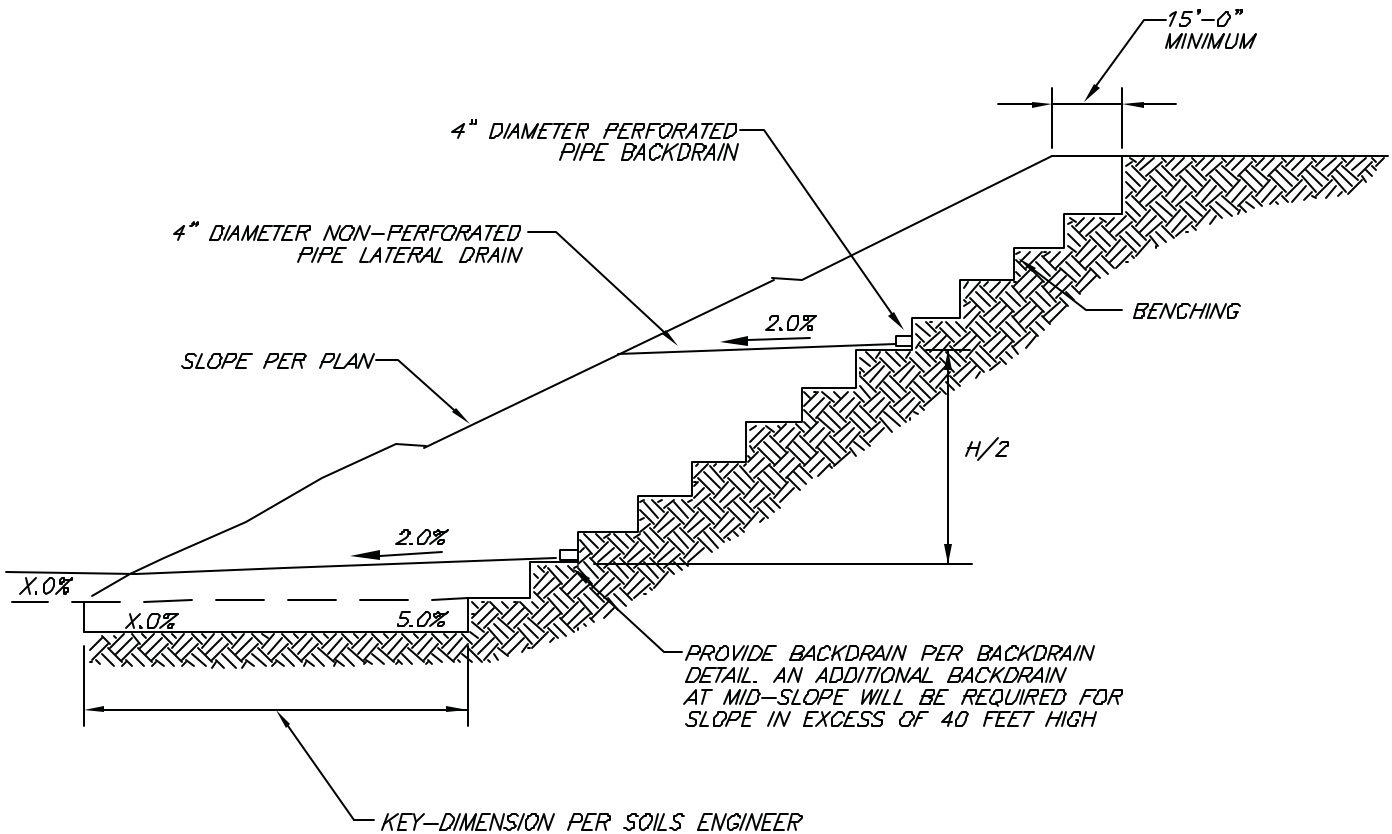

**TYPICAL BUTTRESS FILL
DETAIL**

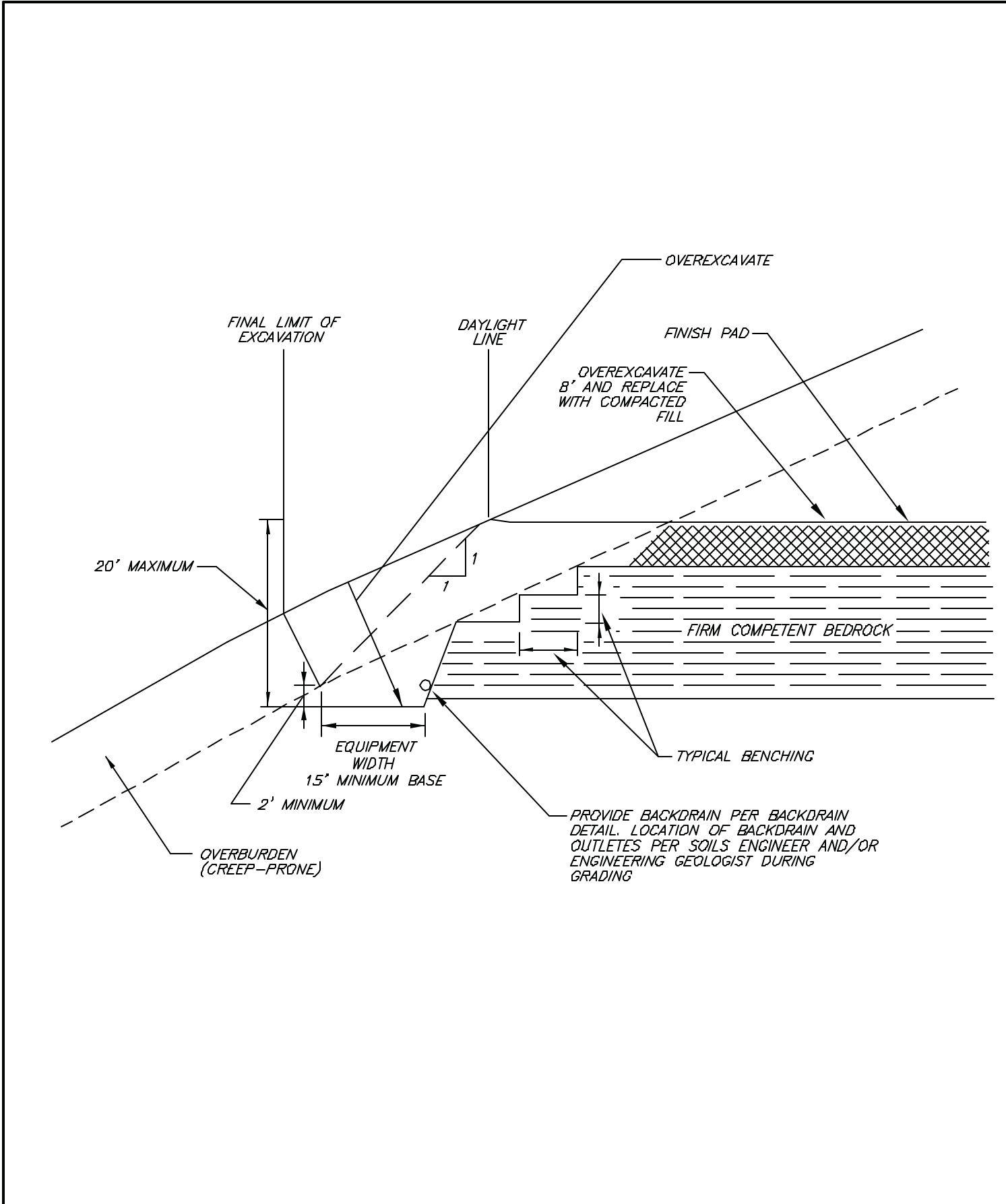

DAYLIGHT SHEAR KEY DETAIL

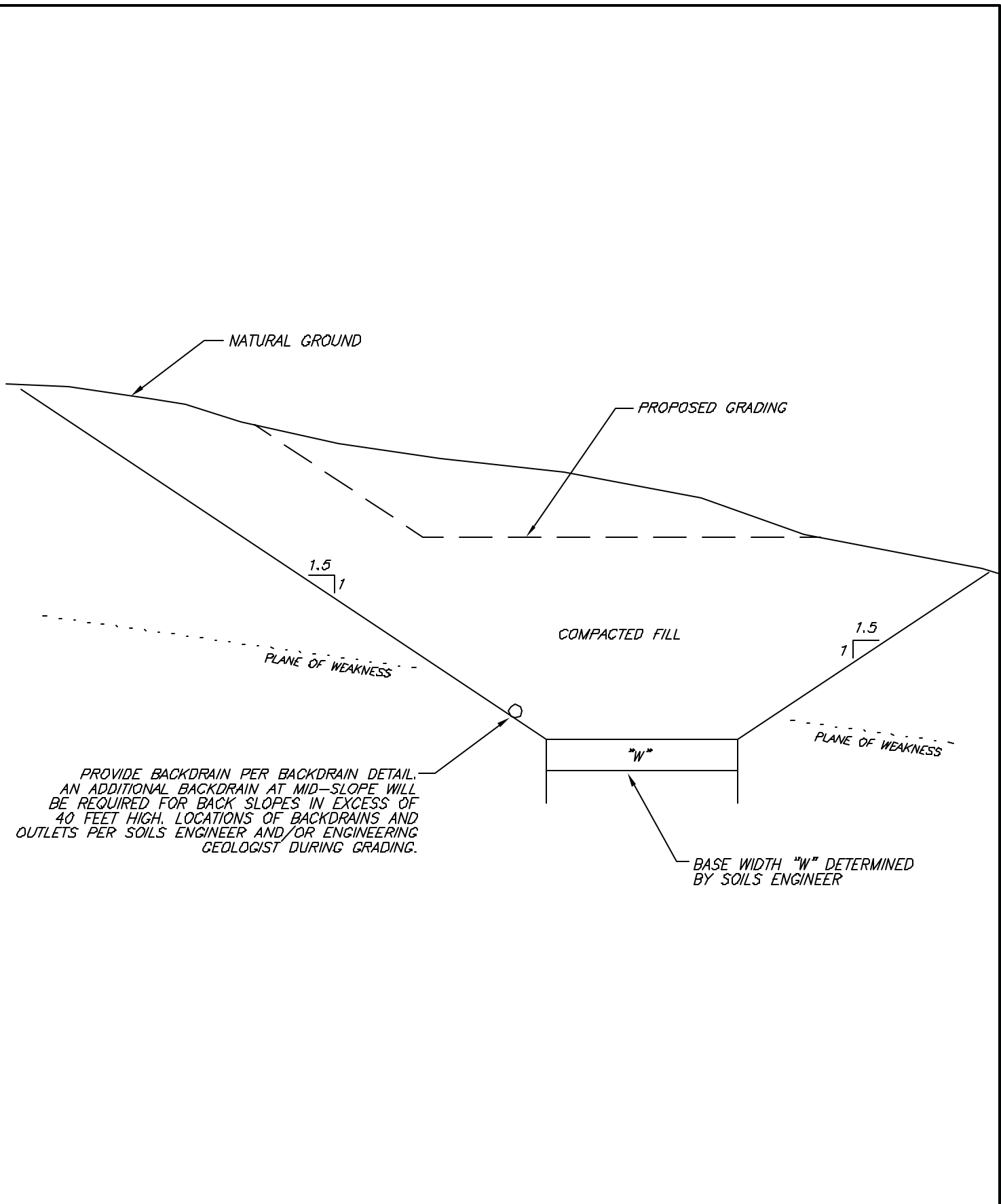

**TYPICAL SHEAR KEY
DETAIL**

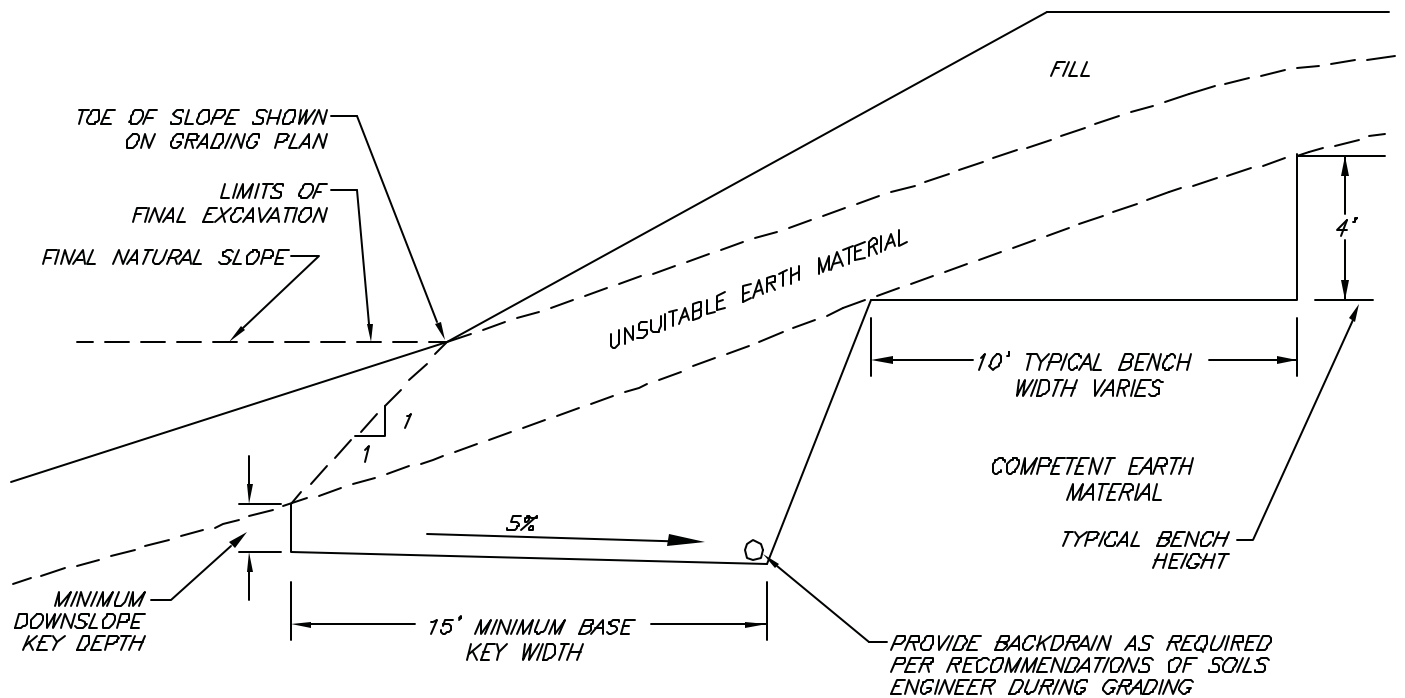

WHERE NATURAL SLOPE IS 5:1 OR LESS,
 BENCHING IS NOT NECESSARY, HOWEVER, FILL IS
 NOT TO BE PLACED ON COMPRESSIBLE OR
 UNSUITABLE MATERIAL.

**FILL SLOPE ABOVE
 NATURAL GROUND DETAIL**

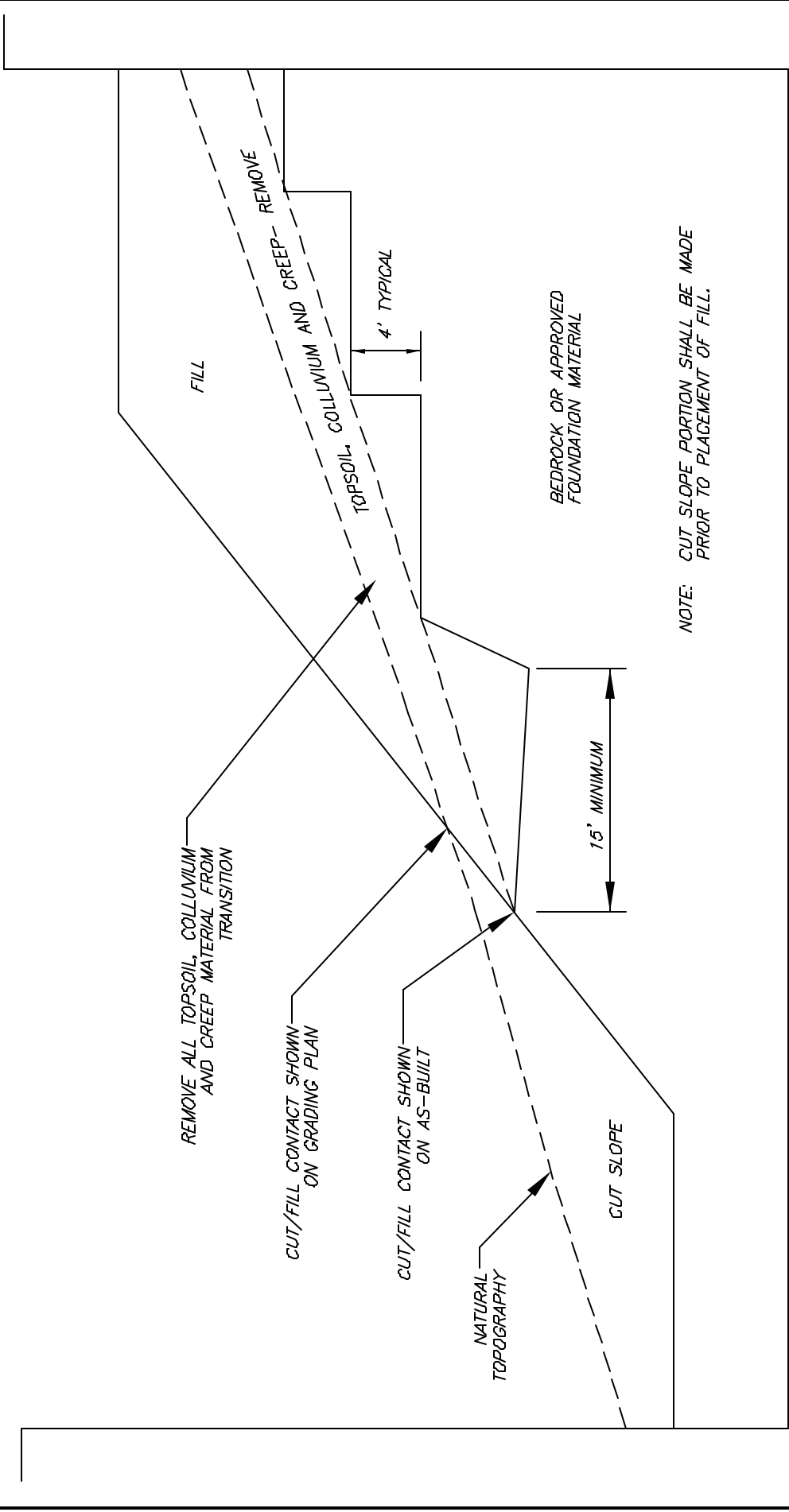

NOTE: CUT SLOPE PORTION SHALL BE MADE PRIOR TO PLACEMENT OF FILL.

FILL SLOPE ABOVE CUT SLOPE DETAIL

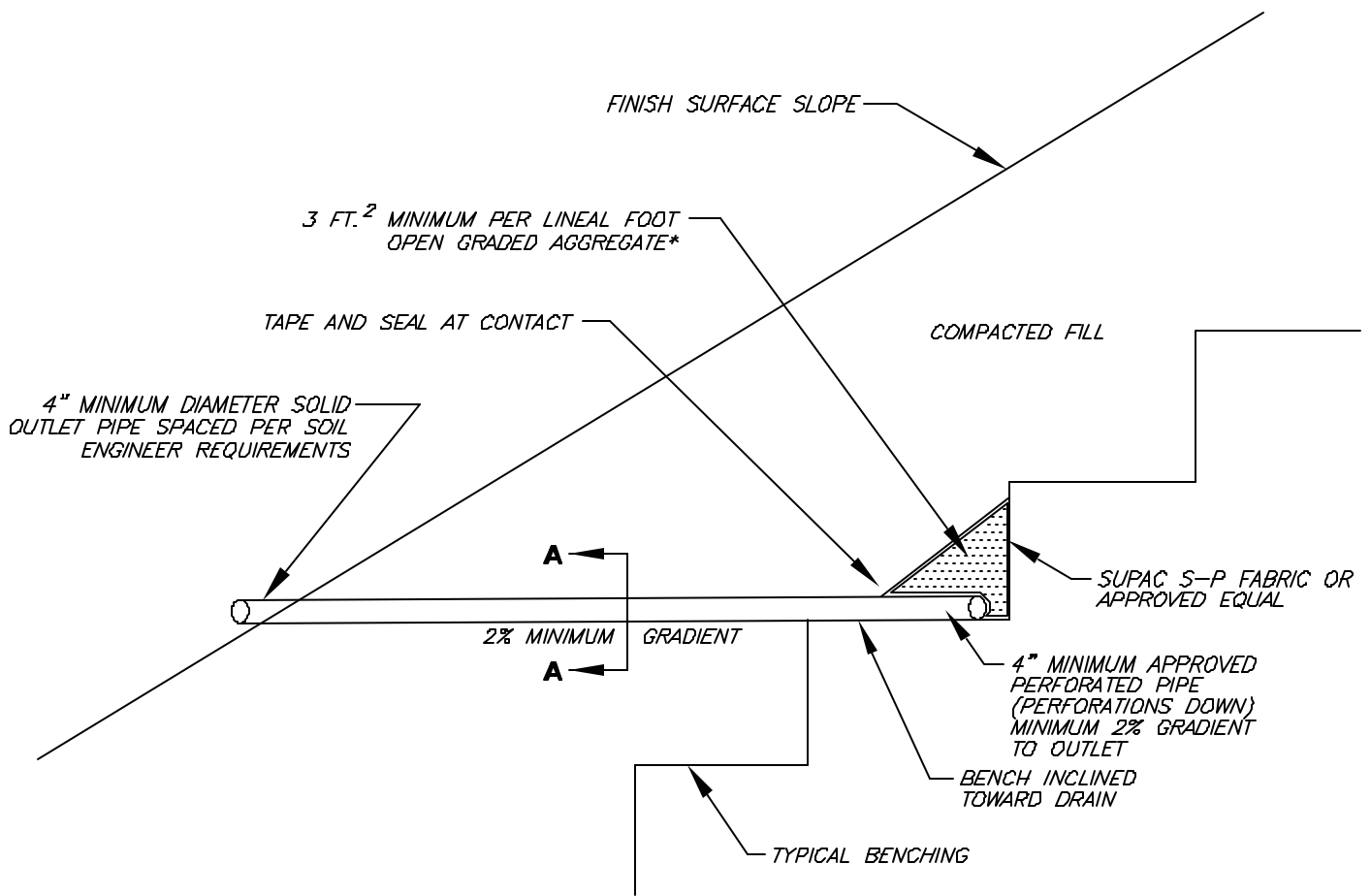

DETAIL A-A

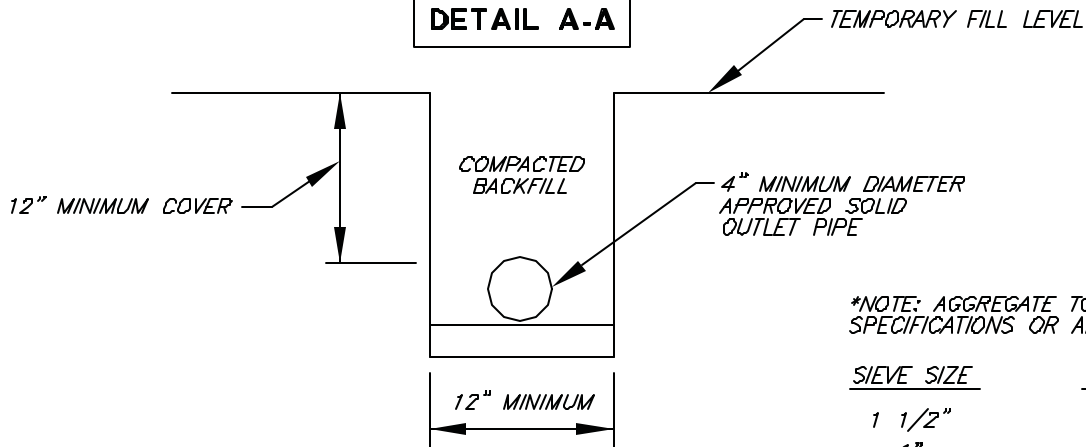

*NOTE: AGGREGATE TO MEET FOLLOWING
SPECIFICATIONS OR APPROVED EQUAL:

<u>SIEVE SIZE</u>	<u>PERCENTAGE PASSING</u>
1 1/2"	100
1"	5-40
3/4"	0-17
3/8"	0-7
NO. 200	0-3

**BACKDRAIN DETAIL
(GEOFABRIC)**

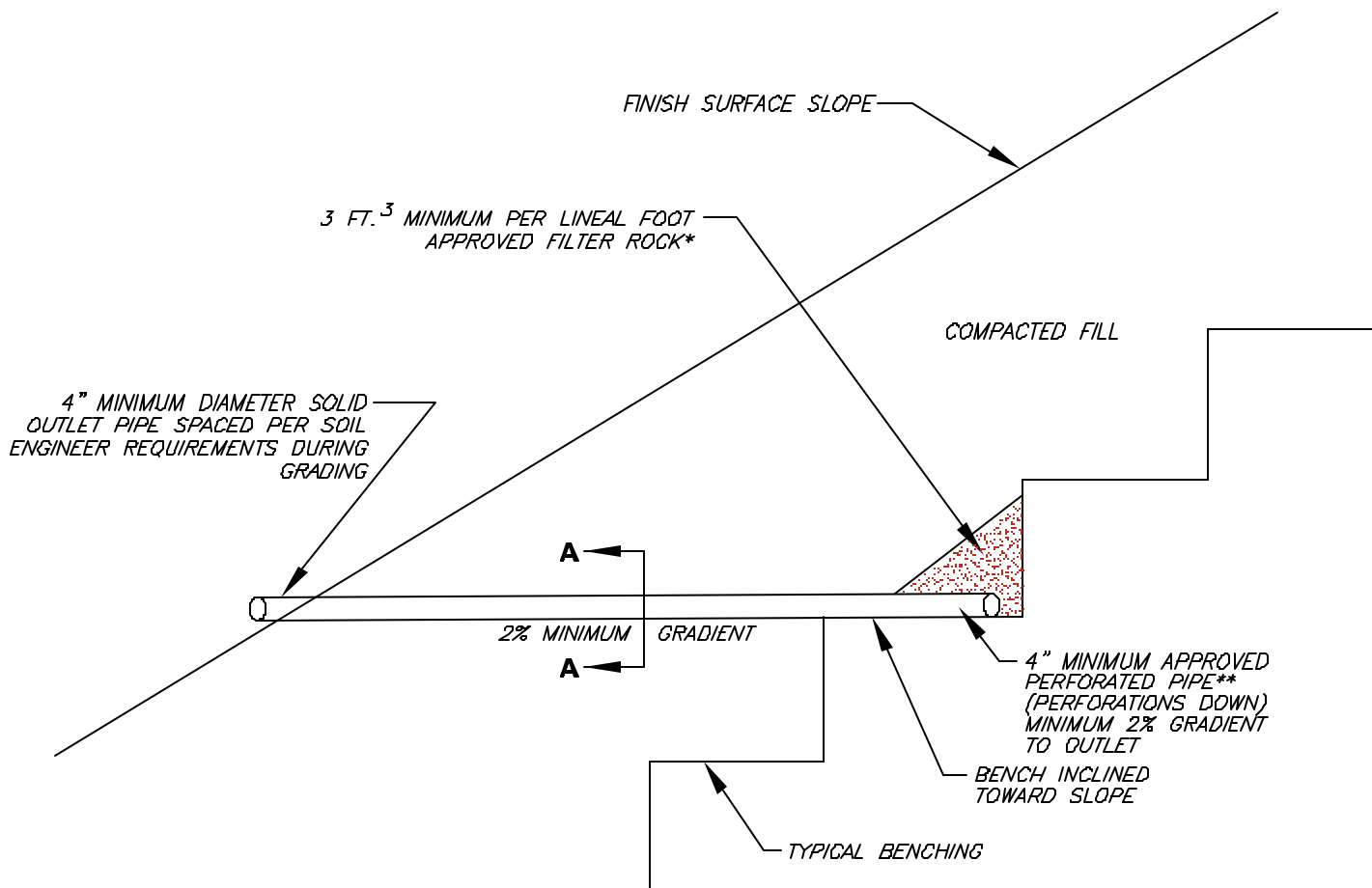

DETAIL A-A

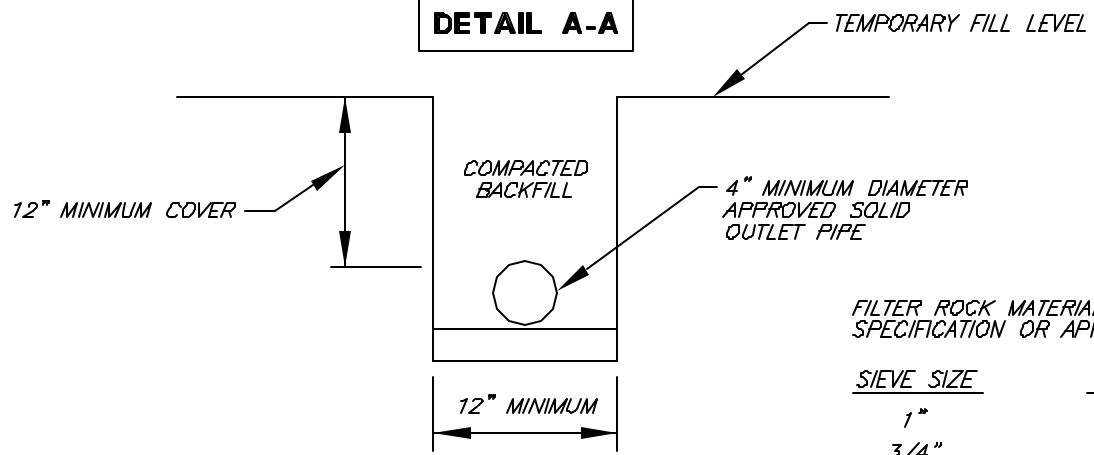

FILTER ROCK MATERIAL TO MEET FOLLOWING SPECIFICATION OR APPROVED EQUAL:

SIEVE SIZE	PERCENTAGE
1"	100
3/4"	90-100
3/8"	40-100
NO. 4	25-40
NO. 30	5-15
NO. 50	0-7
NO. 200	0-3

**APPROVED PIPE TYPE:
 SCHEDULE 40 POLYVINYL CHLORIDE (P.V.C.) OR APPROVED EQUAL.
 MINIMUM CRUSH STRENGTH 1000 PSI.

TYPICAL BACKDRAIN DETAIL

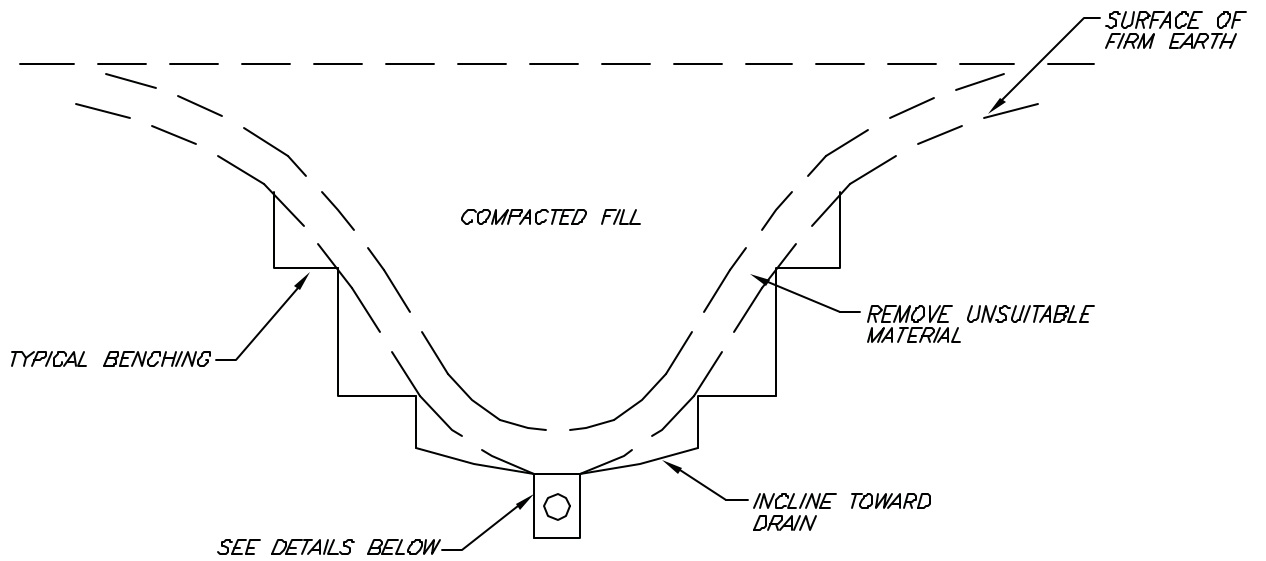

TRENCH DETAIL

6" MINIMUM OVERLAP

OPTIONAL V-DITCH DETAIL

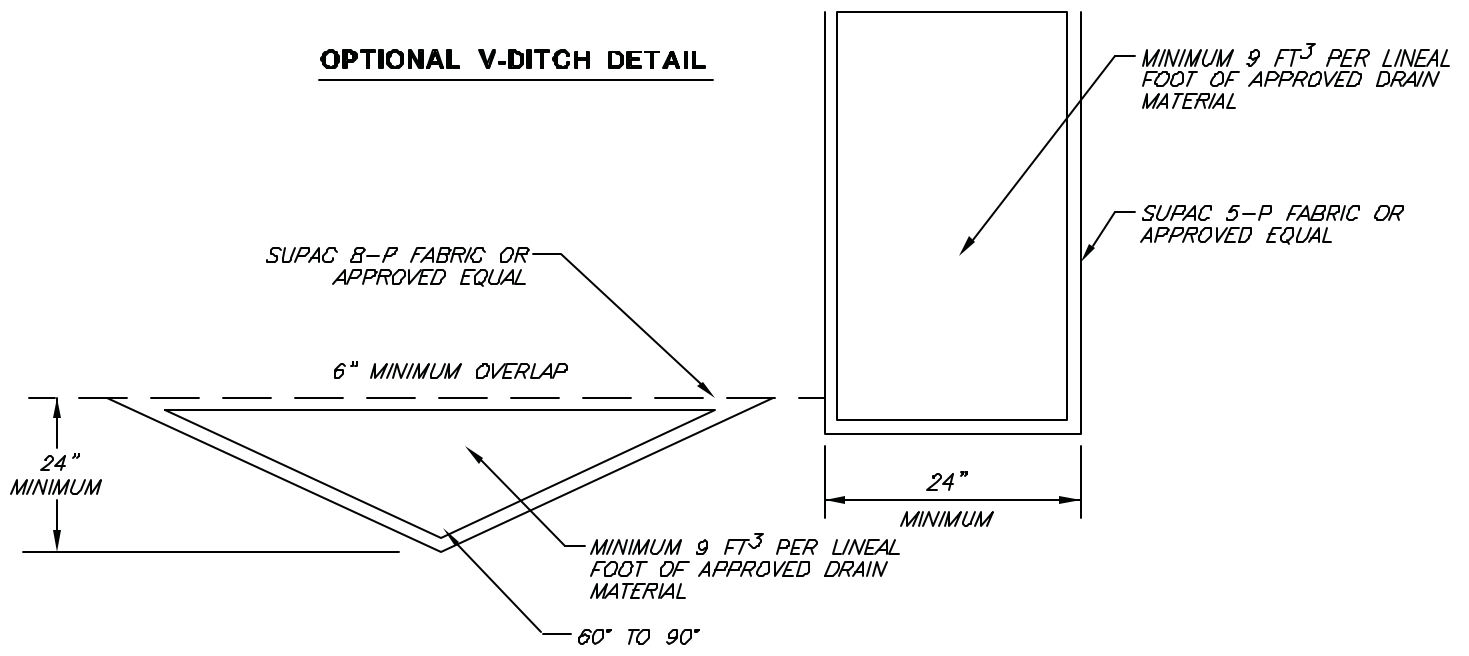

DRAIN MATERIAL TO MEET FOLLOWING SPECIFICATION OR APPROVED EQUAL:

SIEVE SIZE	PERCENTAGE PASSING
1-1/2"	88-100
1"	5-40
3/4"	0-17
3/8"	0-7
NO.:200	0-3

ADD MINIMUM 4" DIAMETER APPROVED PERFORATED PIPE WHEN GRADIENT IS LESS THAN 2%

APPROVED PIPE TO BE SCHEDULE 40 POLY-VINYL-CHLORIDE (P.V.C.) OR APPROVED EQUAL. MINIMUM CRUSH STRENGTH 1000 psi.

GEOFABRIC SUBDRAIN DETAIL

BENCHING FILL OVER NATURAL

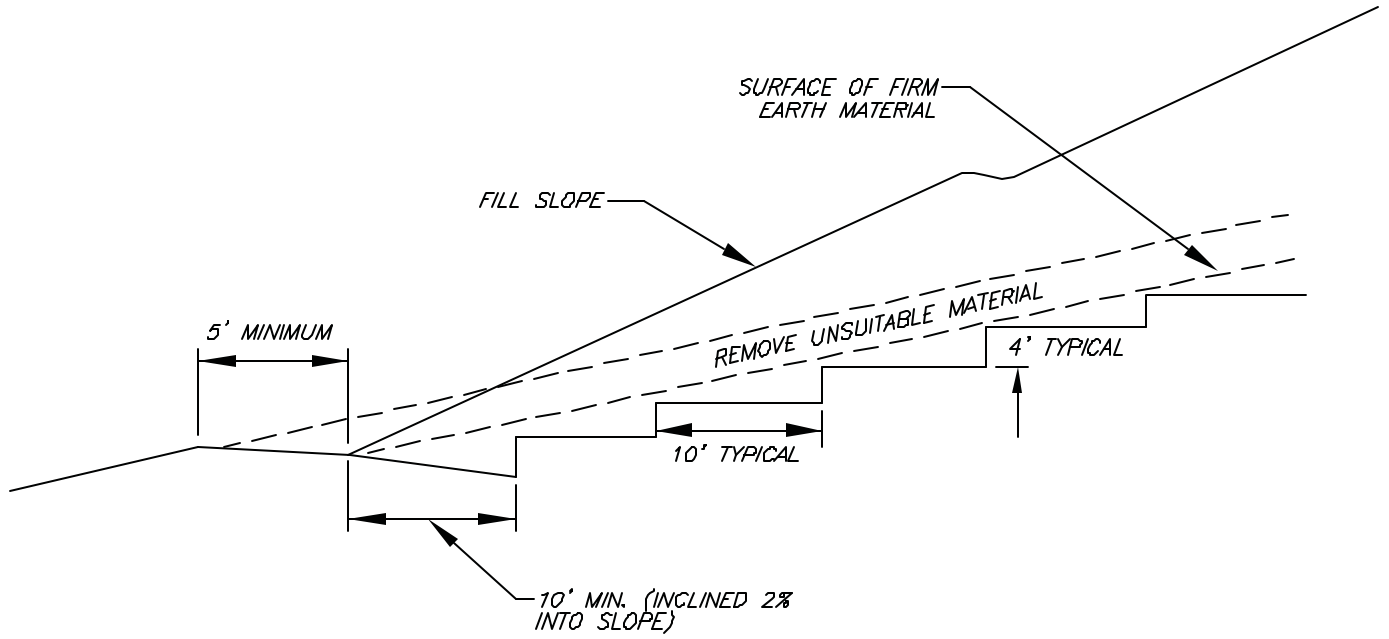

BENCHING FILL OVER CUT

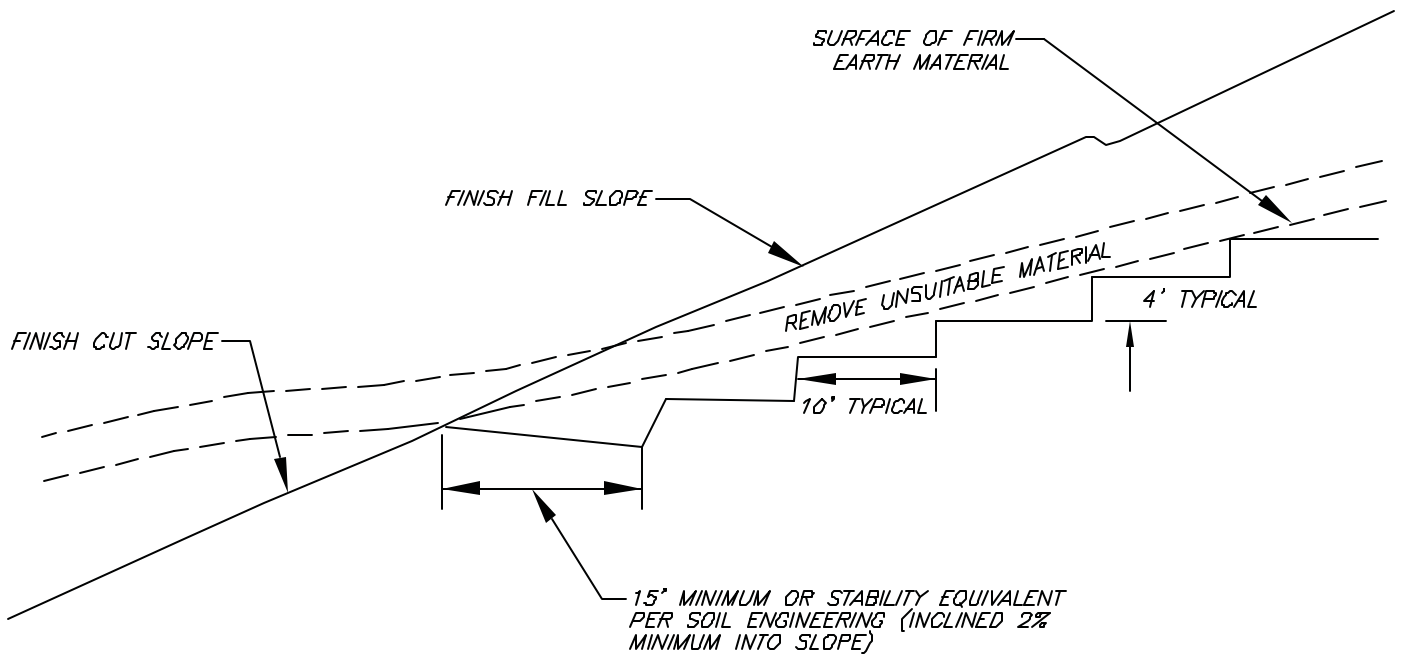

BENCHING FOR COMPACTED FILL DETAIL

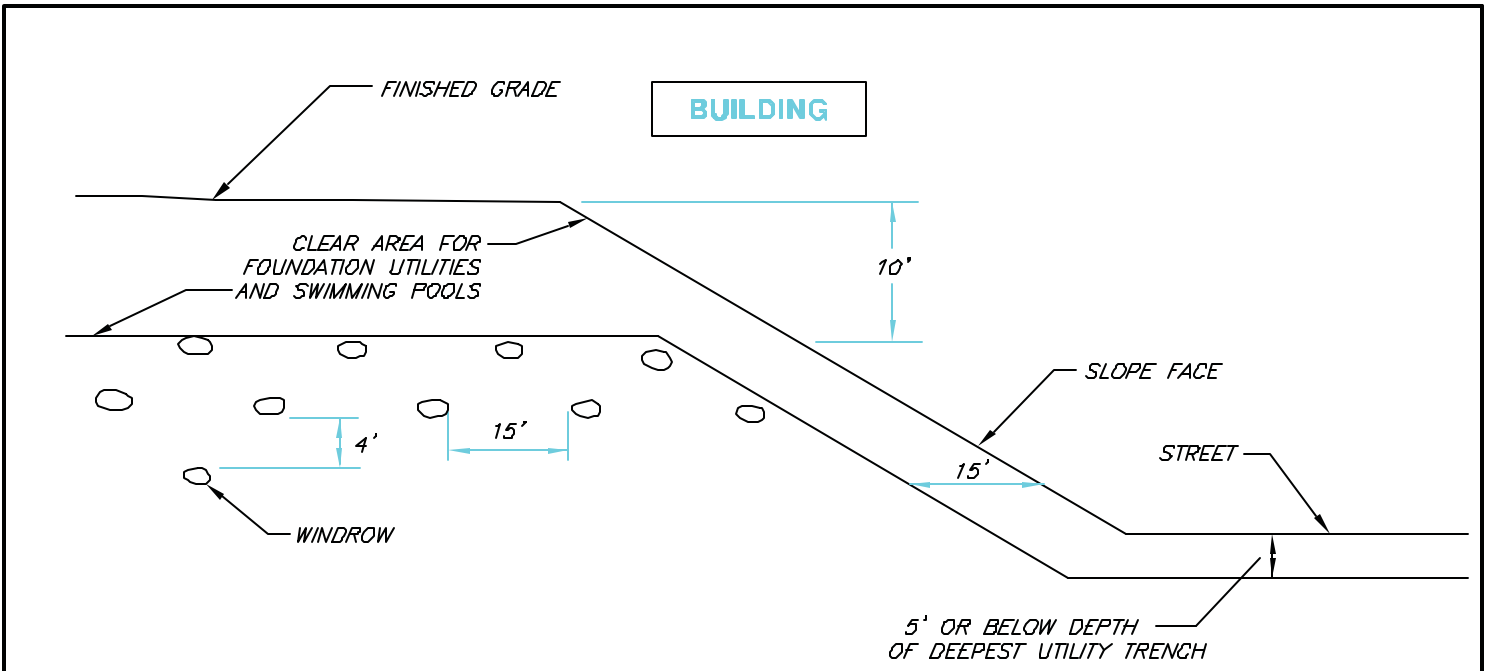

TYPICAL WINDROW DETAIL (EDGE VIEW)

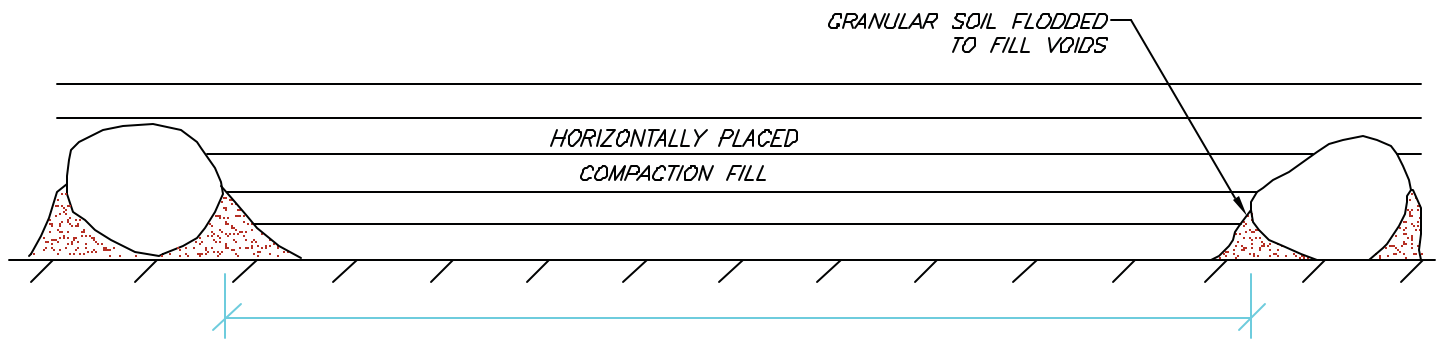

PROFILE VIEW

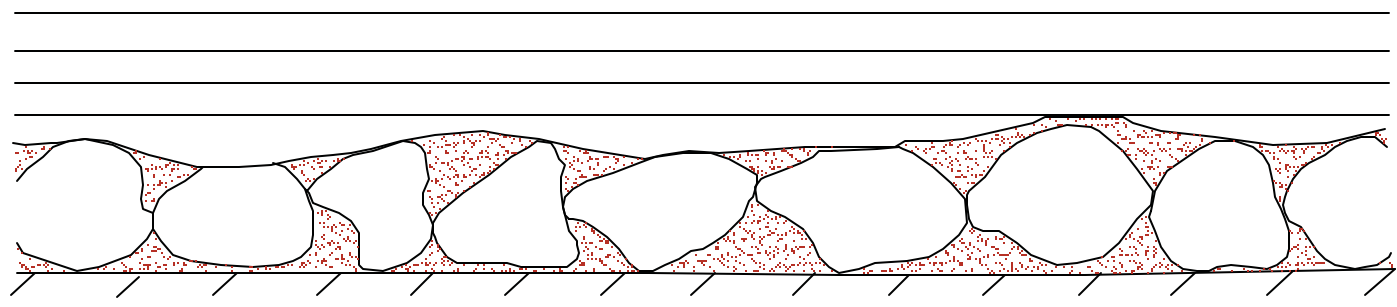

ROCK DISPOSAL DETAIL

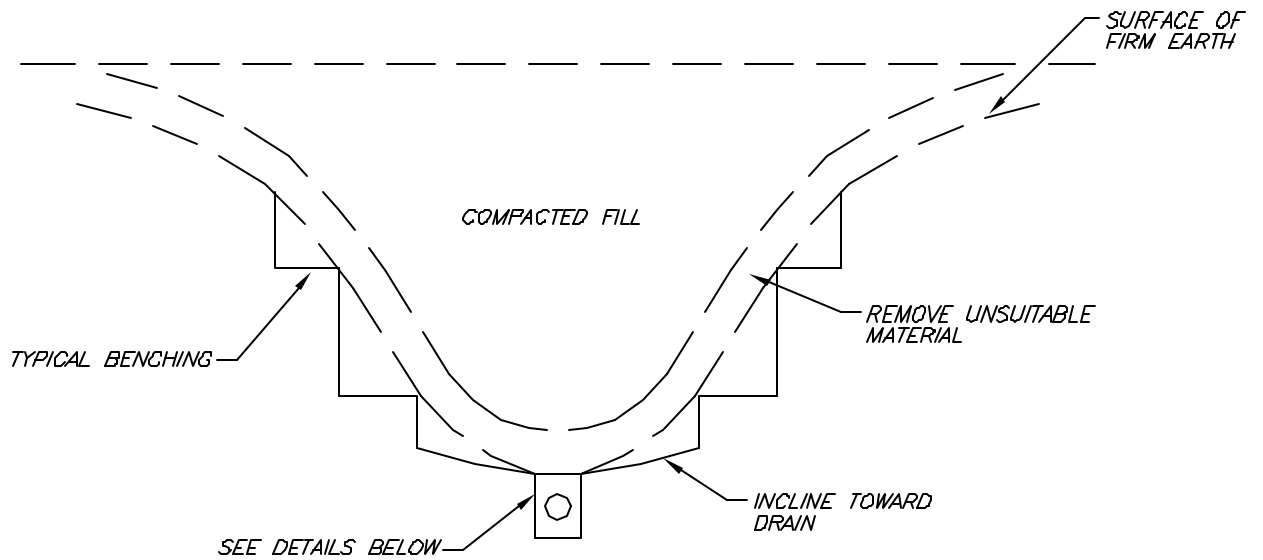

TRENCH DETAIL

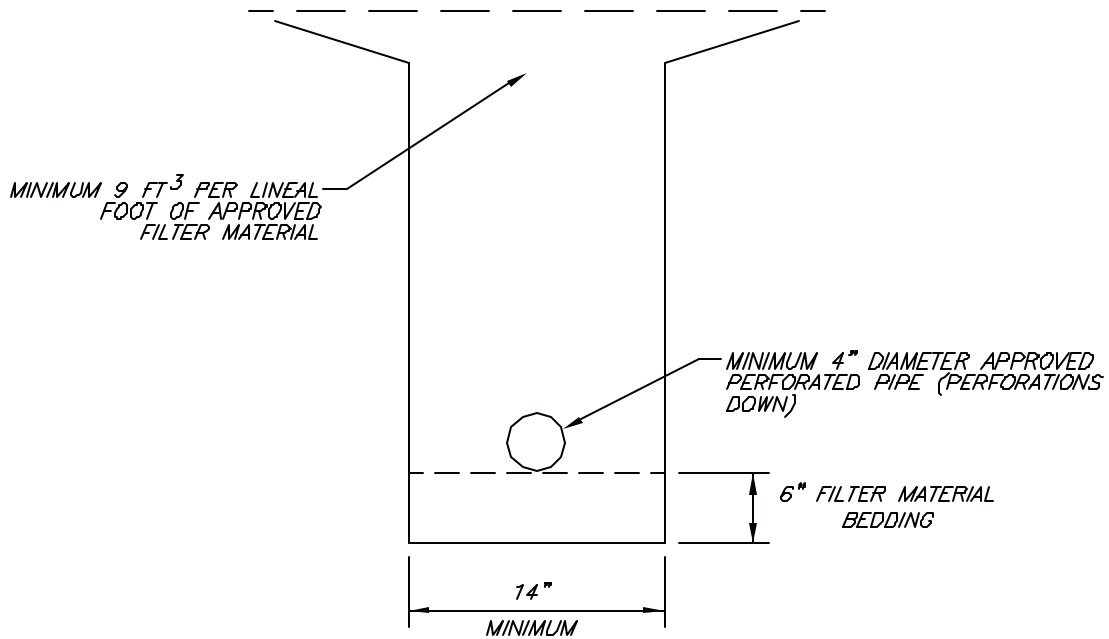

FILTER MATERIAL TO MEET FOLLOWING SPECIFICATION OR APPROVED EQUAL:

SIEVE SIZE	PERCENTAGE
1"	100
3/4"	90-100
3/8"	40-100
NO. 4	25-40
NO. 30	5-15
NO. 50	0-7
NO. 200	0-3

APPROVED PIPE TO BE SCHEDULE 40 POLY-VINYL-CHLORIDE (P.V.C.) OR APPROVED EQUAL. MINIMUM CRUSH STRENGTH 1000 psi.

PIPE DIAMETER TO MEET THE FOLLOWING CRITERIA. SUBJECT TO FIELD REVIEW BASED ON ACTUAL GEOTECHNICAL CONDITIONS ENCOUNTERED DURING GRADING.

LENGTH OF RUN	PIPE DIAMETER
UPPER 500'	4"
NEXT 1000'	6"
> 1500'	8"

**TYPICAL CANYON SUBDRAIN
DETAIL**

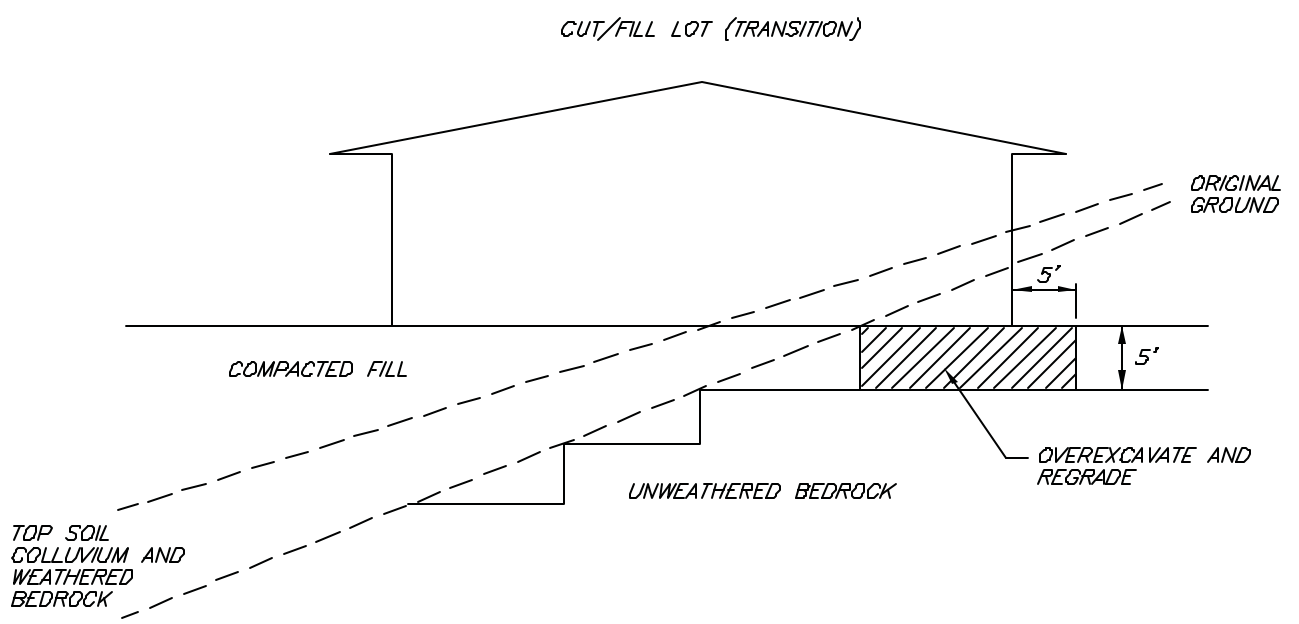
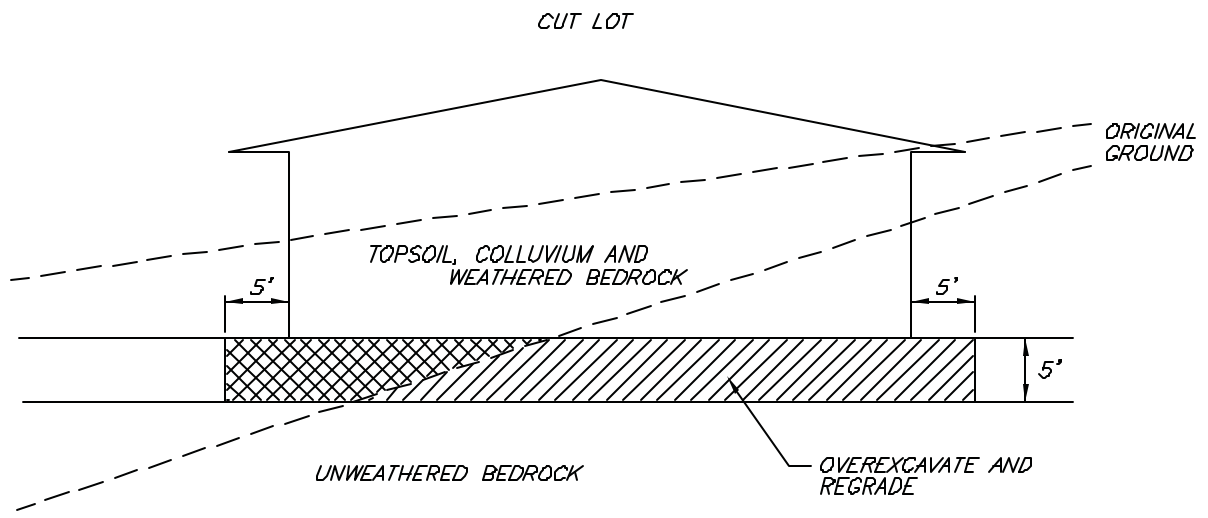

TRANSITION LOT DETAIL